

# 415 L LS 24V

## Swing Gate Operator



**Intertek**

UL325 - UL991

FAAC International Inc.  
Headquarter & East Coast Operations  
5151 Sunbeam Road  
Suites 9-11  
Jacksonville, FL 32257  
Tel. 866 925 3222  
[www.faacusa.com](http://www.faacusa.com)

FAAC International Inc.  
West Coast Operations  
357 South Acacia Avenue  
Unit 357  
Fullerton, CA 92831  
Tel. 800 221 8278

# FAAC

## CONTENTS

---

<b>IMPORTANT SAFETY INFORMATION</b>	<b>3</b>
Important Safety Instructions	3
Important Installation Instructions	3
General Safety Precautions	4
UL325 Gate Operator Classifications	5
Installing the Warning Signs	5
<b>1. DESCRIPTION</b>	<b>6</b>
<b>2. DIMENSIONS</b>	<b>6</b>
<b>3. TECHNICAL SPECIFICATIONS</b>	<b>7</b>
<b>4. INSTALLATION</b>	<b>7</b>
4.1 Electrical Set-up (Standard System)	7
4.2 Preliminary Checks	7
4.3 Installation Dimensions	8
4.4 Installing the Operator	9
4.5 Wiring the Operator	10
4.6 Adjusting the Limit Switches	11
4.7. Start-up	12
<b>5. MANUAL OPERATION</b>	<b>12</b>
<b>6. MAINTENANCE</b>	<b>13</b>
<b>7. REPAIRS</b>	<b>13</b>
<b>8. 415 L LS PARTS DIAGRAM</b>	<b>14</b>
<b>E024U CONTROL BOARD AND LIMITED WARRANTY</b>	<b>A2 - A18</b>



Read this instruction manual before you begin installing the product.  
 = Information regarding personal safety and proper maintenance of the product.

## IMPORTANT SAFETY INFORMATION

### Important Safety Instructions

#### WARNING: TO REDUCE THE RISK OF SEVERE INJURY OR DEATH:

- READ AND FOLLOW ALL INSTRUCTIONS.
- Never let children operate or play with the gate controls. Keep remote controls away from children.
- Always keep people and objects away from the gate. NO ONE SHOULD CROSS THE PATH OF A MOVING GATE.
- Test the gate operator monthly. The gate MUST reverse on contact with a rigid object or when an object activates a non-contact sensor. If necessary, adjust the force or the limit of travel and then retest the gate operator. Failure to properly adjust and retest the gate operator can increase the risk of injury or death.
- Use the manual release mechanism only when the gate is not moving.
- KEEP GATE PROPERLY MAINTAINED. Have a qualified service person make repairs to gate hardware.
- The entrance is for vehicles only. Pedestrians must use a separate entrance.
- SAVE THESE INSTRUCTIONS.

### Important Installation Instructions

1. Install the gate operator only when the following conditions have been met:
  - The operator is appropriate for the type and usage class of the gate.
  - All openings of a horizontal slide gate have been guarded or screened from the bottom of the gate to a minimum of 4 feet (1.25 m) above the ground to prevent a 2.25 inch (55 mm) diameter sphere from passing through openings anywhere in the gate or through that portion of the adjacent fence that the gate covers when in the open position.
  - All exposed pinch points are eliminated or guarded.
  - Guarding is supplied for exposed rollers.
2. The operator is intended for installation on gates used by vehicles only. Pedestrians must be provided with a separate access opening.
3. To reduce the risk of entrapment when opening and closing, the gate must be installed in a location that allows adequate clearance between the gate and adjacent structures. Swinging gates shall not open outward into public access areas.
4. Before installing the gate operator, ensure that the gate has been properly installed and that it swings freely in both directions. Do not over-tighten the operator clutch or pressure relief valve to compensate for a damaged gate.
5. User controls must be installed at least 6 feet away from any moving part of the gate and located where the user is prevented from reaching over, under, around or through the gate to operate the controls. Controls located outdoors or those that are easily accessible shall have security features to prevent unauthorized use.
6. The Stop and/or Reset buttons must be located within line-of-sight of the gate. Activation of the reset control shall not cause the operator to start.
7. All warning signs and placards must be installed and easily seen within visible proximity of the gate. A minimum of one warning sign shall be installed on each side of the gate.
8. For gate operators that utilize a non-contact sensor (photo beam or the like):
  - See instructions on the placement of non-contact sensors for each type of application.
  - Exercise care to reduce the risk of nuisance tripping, such as when a vehicle trips the sensor while the gate is still moving.
  - Locate one or more non-contact sensors where the risk of entrapment or obstruction exists, such as at the reachable perimeter of a moving gate or barrier.
  - Use only FAAC "Photobeam" photoelectric eyes to comply with UL325.

*Important Installation Instructions (continued)*

9. For gate operators that utilize a contact sensor (edge sensor or similar):
  - Locate one or more contact sensors where the risk of entrapment or obstruction exists, such as at the leading edge, trailing edge, and post mounted both inside and outside of a vehicular horizontal slide gate
  - Locate one or more contact sensors at the bottom edge of a vehicular vertical lift gate.
  - Locate one or more contact sensors at the bottom edge of a vertical barrier (arm).
  - Locate one or more contact sensors at the pinch point of a vehicular vertical pivot gate.
  - Locate hard-wired contact sensors and wiring so that communication between sensor and gate operator is not subjected to mechanical damage.
  - Locate wireless contact sensors, such as those that transmit radio frequency (RF) signals, where the transmission of signals are not obstructed or impeded by building structures, natural landscaping or similar hindrances. Wireless contact sensors shall function under their intended end-use conditions.
  - Use only FAAC MSE MO, CN60 or M60 edge sensors.

**General Safety Precautions****Gate Construction**

**Vehicular gates should be constructed and installed in accordance with ASTM F2200: Standard Specification for Automated Vehicular Gate Construction.**

For more information, contact ASTM at: [www.astm.org](http://www.astm.org)

**Installation**

- If you have any questions or concerns regarding the safety of the gate operating system, do not install the operator and consult the manufacturer.
- The condition of the gate structure itself directly affects the reliability and safety of the gate operator.
- Only qualified personnel should install this equipment. Failure to meet this requirement could cause severe injury and/or death, for which the manufacturer cannot be held responsible.
- The installer must provide a main power switch that meets all applicable safety regulations.
- It is extremely unsafe to compensate for a damaged gate by increasing hydraulic pressure.
- Install devices such as reversing edges and photo beams to provide better protection for personal property and pedestrians. Install reversing devices that are appropriate to the gate design and application.
- Before applying electrical power, ensure that voltage requirements of the equipment correspond to the supply voltage. Refer to the label on your gate operator system.

**Usage**

- Use this equipment only in the capacity for which it was designed. Any use other than that stated should be considered improper and therefore dangerous.
- The manufacturer cannot be held responsible for damage caused by improper, erroneous or unreasonable use.
- If a gate system component malfunctions, disconnect the main power before attempting to repair it.
- Do not impede the movement of the gate, you may injure yourself or damage the gate system as a result.
- This equipment may reach high thermal temperatures during normal operation, therefore use caution when touching the external housing of the gate operator.
- Use the manual release mechanism according to the procedures presented in this manual.
- Before performing any cleaning or maintenance operations, disconnect power to the equipment.
- All cleaning, maintenance or repair work must be performed by qualified personnel.

## ***UL325 Gate Operator Classifications***

---

### **RESIDENTIAL VEHICULAR GATE OPERATOR CLASS I**

A vehicular gate operator system intended for use in a single family dwelling, garage or associated parking area.

---

### **COMMERCIAL / GENERAL ACCESS VEHICULAR GATE OPERATOR CLASS II**

A vehicular gate operator system intended for use in commercial locations or buildings such as multi-family housing units (five or more single family units), hotels, parking garages, retail stores or other buildings that service the general public.

---

### **INDUSTRIAL / LIMITED ACCESS VEHICULAR GATE OPERATOR CLASS III**

A vehicular gate operator system intended for use in industrial locations or buildings such as factories, loading docks or other locations not intended to service the general public.

---

### **RESTRICTED ACCESS VEHICULAR GATE OPERATOR CLASS IV**

A vehicular gate operator system intended for use in guarded industrial locations or buildings such as airport security areas or other restricted access locations that do not service the general public, and in which unauthorized access is prevented via supervision by security personnel.

---

## ***Installing the Warning Signs***

---

This FAAC swing gate operator is supplied with two warning signs to alert people that a possible hazard exists and that appropriate actions should be taken to avoid the hazard or to reduce exposure to it.

Permanently install one warning sign on each side of the gate so they are fully visible to traffic and pedestrians.

Use appropriate hardware such as metal screws (not supplied) to permanently install each warning sign.



## Model 415 L LS 24V Swing Gate Operator

### 1. DESCRIPTION

The FAAC 415 is an automatic gate operator for swinging gate leaves. The 415 Operator is useful in residential applications and can accommodate gate leaves up to 14 ft long. The self-contained 415 Operator consists of an electric motor that drives a worm screw housed in an aluminum casing.

The locking provided by the 415 Operator (in the fully opened and fully closed positions) is a service device rather than a security device.

Also, for the protection and proper operation of the 415 Operator, each operator has built in limit switches, so positive stops are not needed.

The 415 Operator automated system was designed and built for controlling vehicle access. Avoid any other use what so ever.

NOTES:

- Use suitable conduit to lay electric cables.
- To avoid any kind of interference, always use individual sheaths to separate low-voltage accessories and control cables from 115V~ power supply cables.

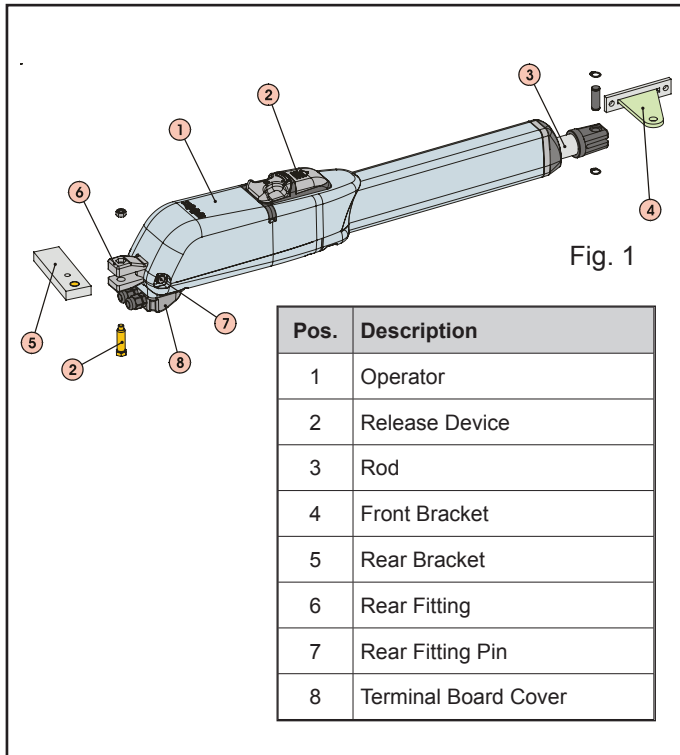

Built-in security and anti-crushing measures of the 415 Operator include built in reverse on contact and a torque adjustment that controls the force transmitted to the gate leaf through the 415 Operator.

The Manual Release mechanism is a key accessed device that disengages (or engages) the cylinder on the 415 Operator. When the drive is disengaged, you can manually open and close the gate leaf by hand.

Such manual operation of the gate is necessary during installation and useful during prolonged power failures. The torque of the 415 Operator is set using the Control Panel.

Reversing devices (such as inductive loops and photocells) should be installed to provide non-contact reversing operation.

### 2. DIMENSIONS

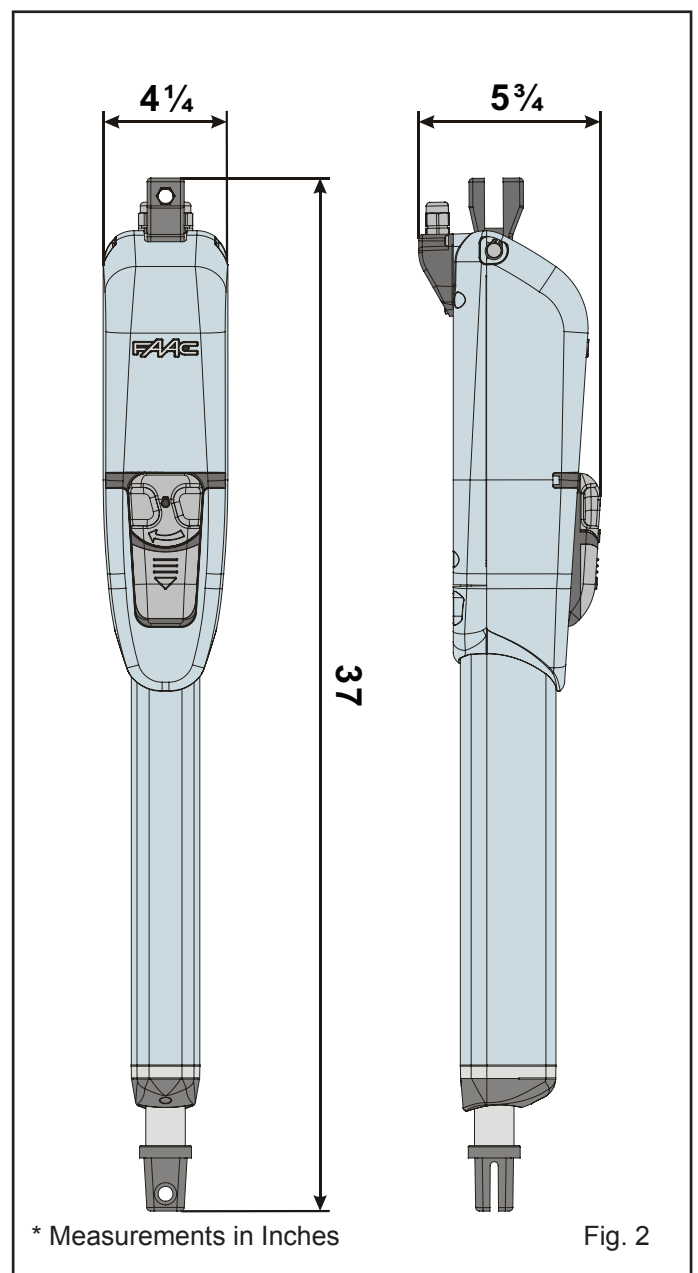

### 3. TECHNICAL SPECIFICATIONS

SPECIFICATION	415 L LS 24V
Power Supply	24 VDC
Power (W)	70
Current (A)	3
Thrust (lbf)	630
Effective Stroke (inches)	15
Rod Extension Speed (inches/sec)	0.5
Max Leaf Length (feet)	15
Cycle per hour at 68°F (approx)	75
Class or Operation	Residential
Ambient Operating Temperature Range (°F)	-4 to +131
Operator Weight (lbs)	17.5
Protection Class	IP 54

### 4. INSTALLATION

#### 4.1 Electrical Set-up (Standard System)

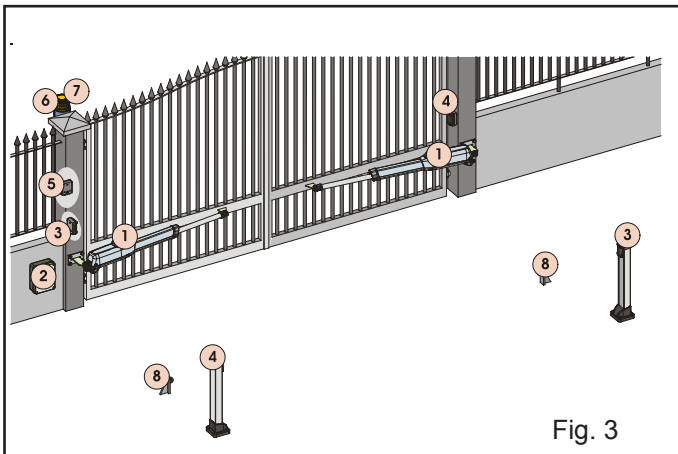

Pos.	Description	Cables
1	Operators	4 x AWG 14
2	Control Unit	3 x AWG 14 (power supply)
3	TX Photocells	4 x AWG 20
4	RX Photocells	2 x AWG 20
5	Key-operated Selector Switch	2 x AWG 20
6	Flashing Lamp	2 x AWG 14
7	Receiver	3 x AWG 20
8	Mechanical Stops	-

#### 4.2 Preliminary Checks

The condition of the gate structure directly affects the reliability and safety of the automated system. Before installing the 415 Operator, prepare the gate for the operator by performing the following:

- Make sure that the gate structure is solidly built. Add reinforcing crosspieces to the gate leaves if necessary.
- Make sure that the gate moves smoothly on its hinges without excessive friction by swinging it opened and closed by hand. If necessary, lubricate all the gate's moving parts.

Positive stops are not needed with the 415 operator, the built limit switches can be used to limit the rod travel

#### 4.3 Installation Dimensions

Determine the mounting position of the operator with reference to Fig. 4.

Ensure that the distance between the open leaf and any obstacles (walls, fences etc.) is greater than the dimensions of the operator.

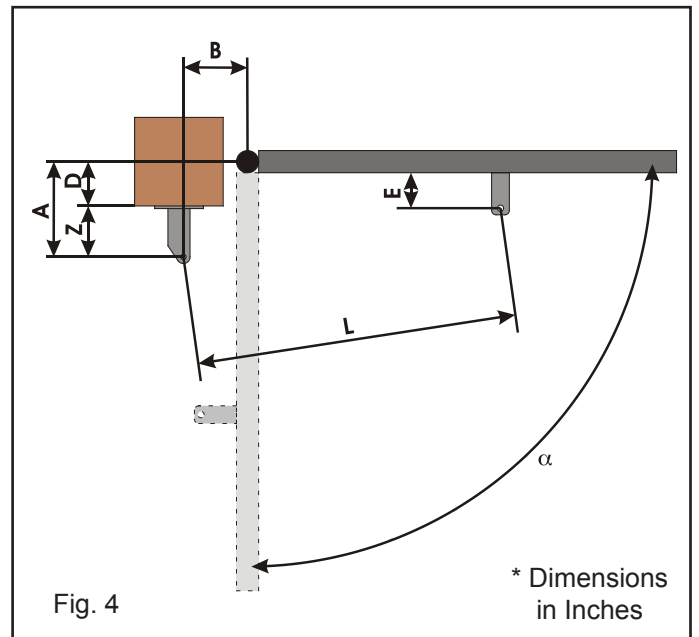

MODEL	415 L LS 24V	
	90°	110°
<b>A</b>	7 <sup>5</sup> / <sub>8</sub>	6 <sup>5</sup> / <sub>8</sub>
<b>B</b>	7 <sup>5</sup> / <sub>8</sub>	6 <sup>5</sup> / <sub>8</sub>
<b>D</b> <sup>(1)</sup>	5	4 <sup>7</sup> / <sub>8</sub>
<b>Z</b> <sup>(2)</sup>	2 <sup>3</sup> / <sub>4</sub>	2 <sup>3</sup> / <sub>4</sub>
<b>L</b>	50 <sup>3</sup> / <sub>4</sub>	50 <sup>3</sup> / <sub>4</sub>
<b>E</b> <sup>(2)</sup>	1 <sup>3</sup> / <sub>4</sub>	
	<sup>(1)</sup> max. dimension	
	<sup>(2)</sup> min. dimension	

### Guidelines for Determining Installation Dimensions

- For **90°** leaf openings: **A+B=C**
- For leaf openings **exceeding 90°**: **A+B<C**
- **Smaller A and B dimensions** provide higher peripheral leaf speed.
- **Limit the difference between A and B dimensions to less than 1.5 inches.** Greater differences may cause speed variations during gate opening and closing movements.
- **Maintain a Z dimension** that ensures that the operator does not strike the pillar.
- **In LS models**, limit switches are triggered during the first and last **1.25 inches of gate travel**. Therefore select **A** and **B** dimensions that utilize the entire operator travel. Short travel ranges can restrict or cancel the limit switch adjustment range.

If pillar dimensions or hinge position do not allow installation of the operator, cut a niche into the pillar (as shown in Fig. 5) in order to maintain the **A** dimension as determined. The dimensions of the niche should enable easy installation, rotation and operation of the release device.

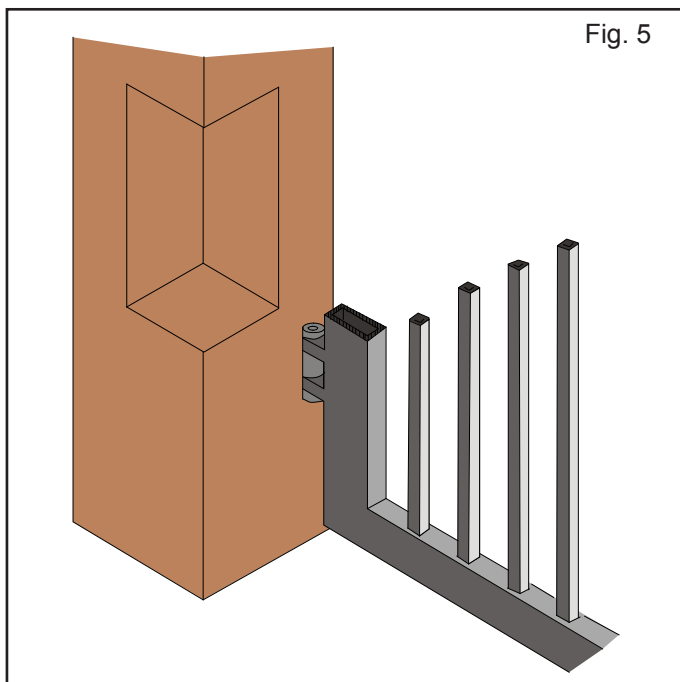

Fig. 5

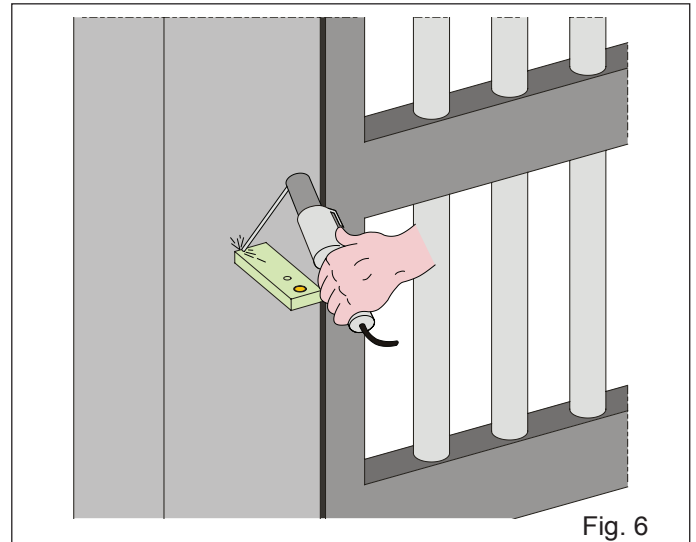

Fig. 6

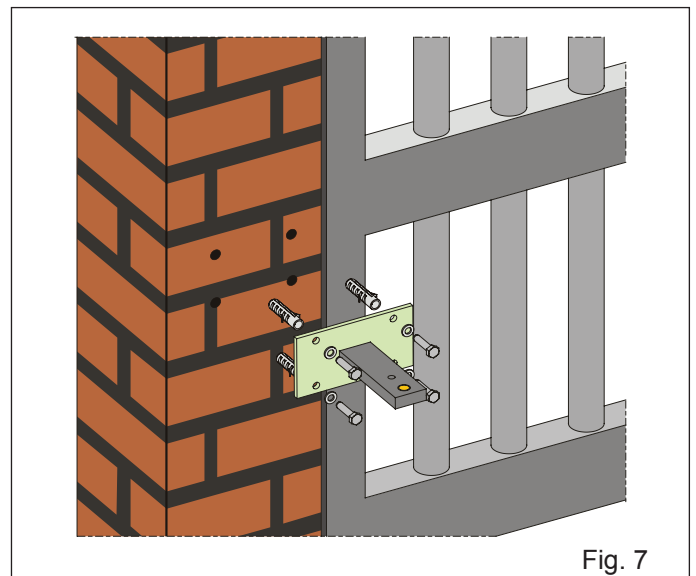

Fig. 7

2. Assemble and attach the rear fitting to the operator (Fig. 8).
3. Set the 415 Operator to manual operation (see Section 6).
4. Completely extend the rod until it reaches the limit stop (Fig. 9, Ref. 1).

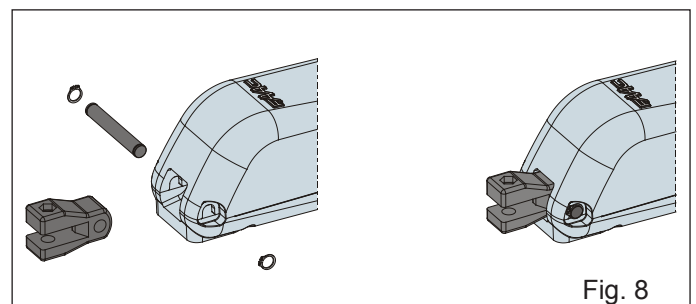

Fig. 8

5. Re-lock the operator (see Section 6.1).

### 4.4. Installing the Operator

1. Fix the rear bracket in the position you previously determined in Section 4.3.1.
  - For iron pillars, carefully weld the bracket directly onto the pillar (Fig. 6).
  - For masonry pillars, use a suitable plate (optional) for which to attach the unit (Fig. 7). Make use of a suitable fastening system. Then carefully weld the bracket to the plate.

**While fastening the bracket, use a level to ensure that it is perfectly horizontal.**



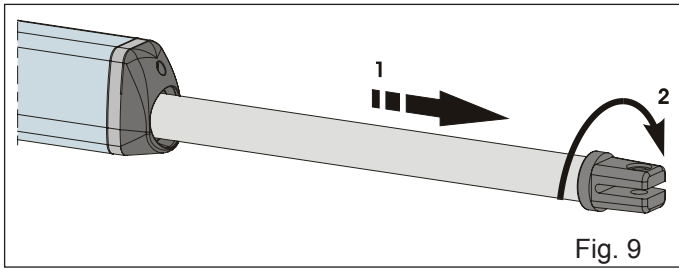

Fig. 9

6. Turn the rod one half revolution clockwise (Fig. 9, Ref. 2).
7. Assemble the front bracket as shown in Fig. 10.
8. Fix the operator to the rear bracket by means of the supplied pins as shown in Fig. 11.

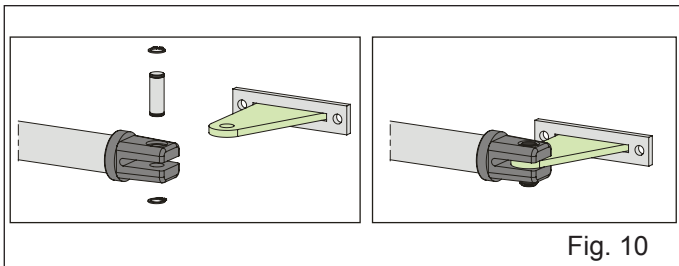

Fig. 10

**Attention: allow the bracket to cool before fastening the operator to it.**

9. Close the leaf and, while keeping the operator perfectly horizontal, determine the fastening point of the front bracket (Fig.12).
10. Temporarily fix the front bracket with two welding spots (Fig.12).

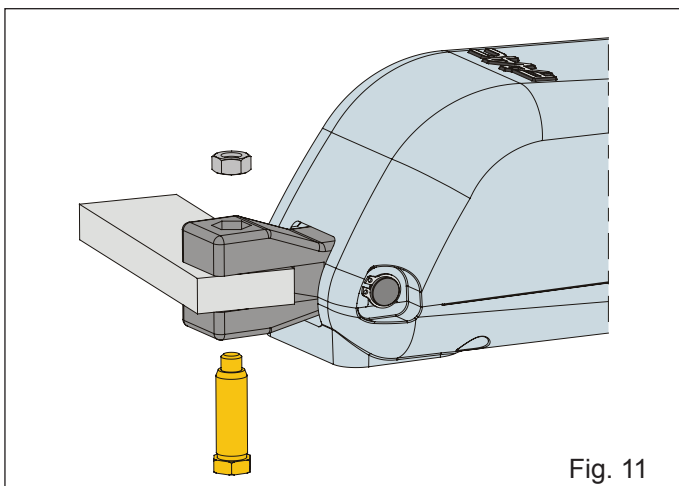

Fig. 11

**Note: if the gate structure does not allow a fixed bracket fastening it is necessary to create a sturdy supporting base in the gate structure.**

11. Release the operator (see Section 6) and manually check that the gate moves regularly without friction or hindrances. Ensure that it opens completely and stops at the mechanical travel stops.

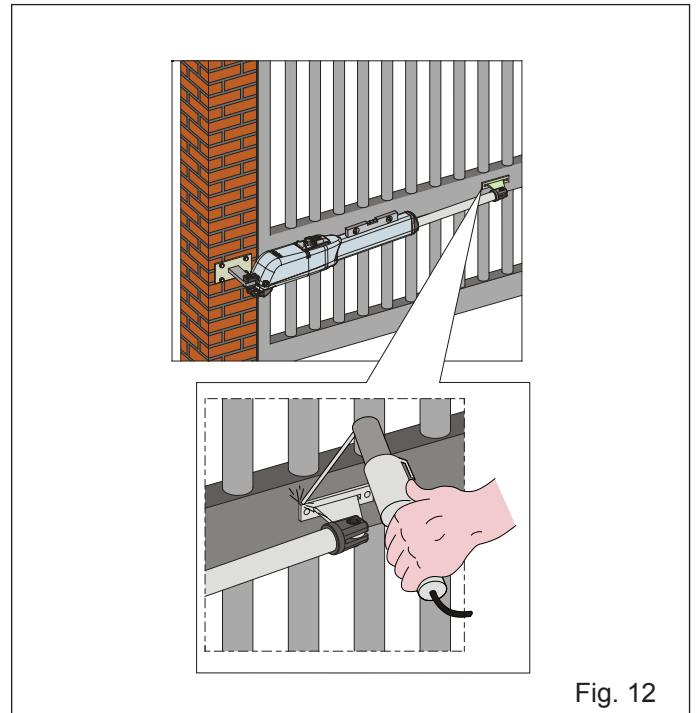

Fig. 12

12. Perform the necessary corrective measures and repeat from Step 11.
13. Temporarily release the operator from the front bracket and permanently weld the bracket.

If the leaf structure prevents the bracket from being welded, screw it to the leaf with adequate securing hardware.

**Note: Grease all fastening pins of the fittings.**

#### 4.5. Wiring the Operator

**IMPORTANT : Use the supplied cable or a similar UL approved cable for outdoor use.**

A terminal block is available in the lower part of the operator to connect the motor and the limit switches

#### Motor Wiring Instructions:

1. Open one of the pre-drilled holes in the supplied cover (Fig.13).
2. Fit the supplied cable gland.
3. Connect the motor (refer to Fig.14 and accompanying table)

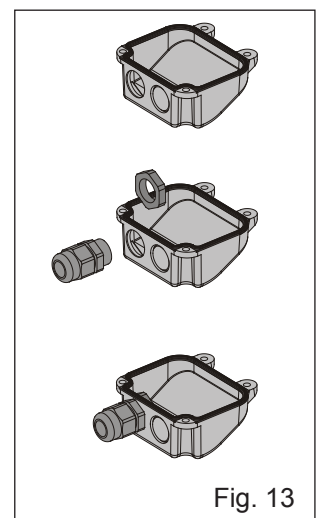

Fig. 13

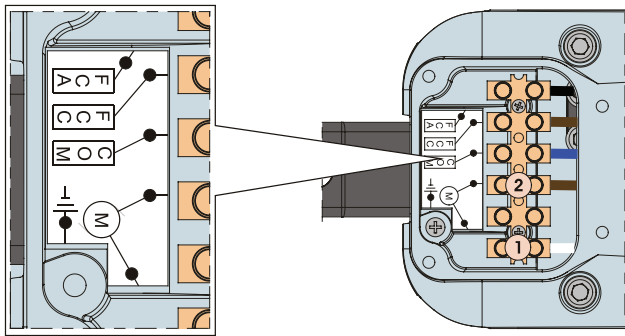

Figure 14 Table Fig. 14

415 (24 VDC)		
POS.	COLOR	DESCRIPTION
1	White	Motor Lead 1
-	Not used	-
2	Brown	Motor Lead 2

**Limit Switches wiring instructions:**

Limit switches are wired in the same terminal block where the motor wiring has been installed. Wire the limit switches as follows:

1. Open the second pre-drilled hole in the cover, see Fig. 15.
2. Fit the supplied cable gland, see Fig. 15.
3. Insert the cable and connect it to the terminals, following the connections specified in Figure 16 Table.

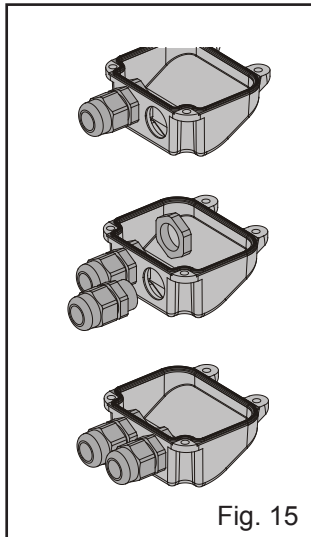

Fig. 15

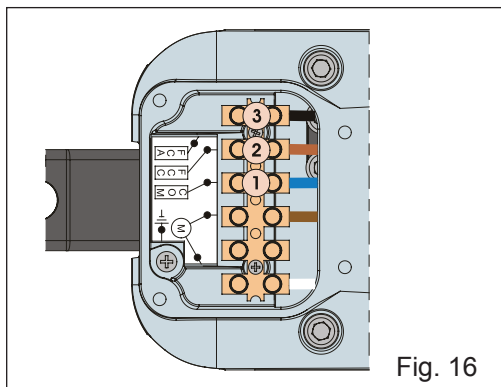

Fig. 16

Figure 16 Table

POS.	COLOR	DESCRIPTION
1	Blue	Common
2	Brown	Closing Limit Switch (FCC)
3	Black	Opening Limit Switch (FCA)

- Close and secure the cover with the four supplied screws (Fig. 17).

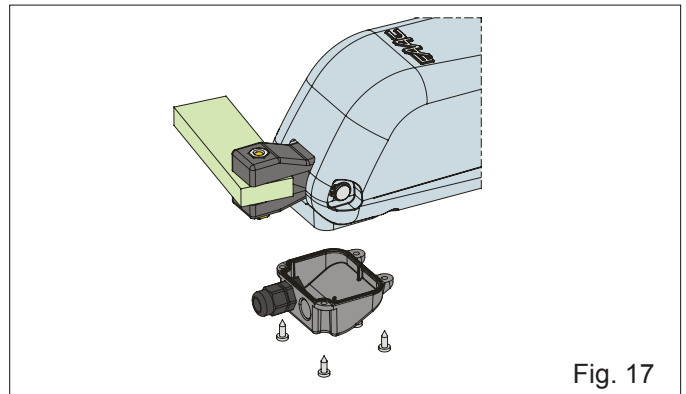

Fig. 17

**4.6 Adjusting the Limit Switches**

**Note:** Limit switches are triggered during the first and the last 1.25 inches of travel. Therefore, the operator should utilize the entire available length of travel during the opening phase. Shorter travels can limit or completely cancel the limit switch adjustment range.

Limit switches adjustment is carried out as follows:

1. Unscrew the upper fastening screw, Fig.18 Ref.A, and remove the cap, Fig.18 Ref.B.

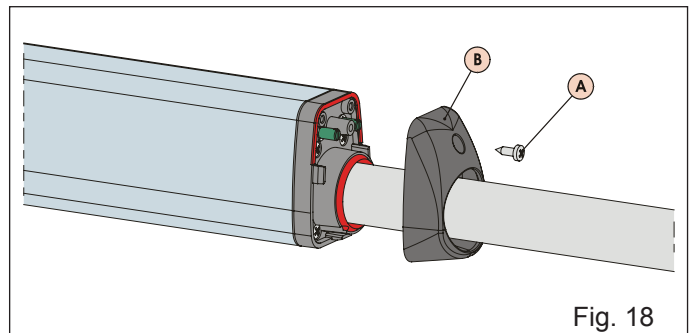

Fig. 18

2. To adjust the closing limit switch FCC, turn the adjusting screw clockwise (Fig.19 Ref.A) to increase rod stroke and counter-clockwise to reduce it.
3. To adjust the opening limit switch FCA, turn the adjusting screw counter-clockwise (Fig. 20 Ref. A) to increase rod stroke and clockwise to reduce it.
4. Perform a pair of test cycles to check the correct position of the limit switch. If the limit switch needs additional adjustment, repeat the operation starting from Step 2.

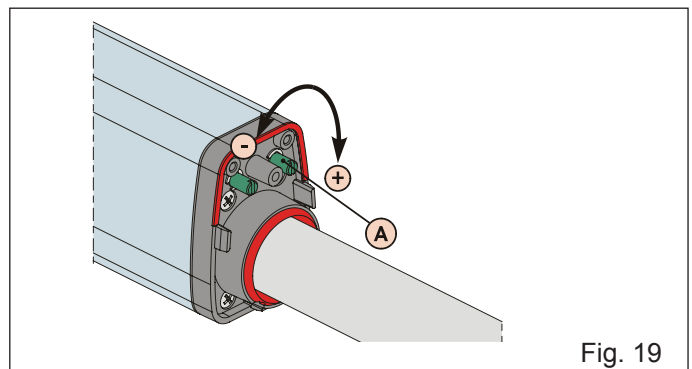

Fig. 19

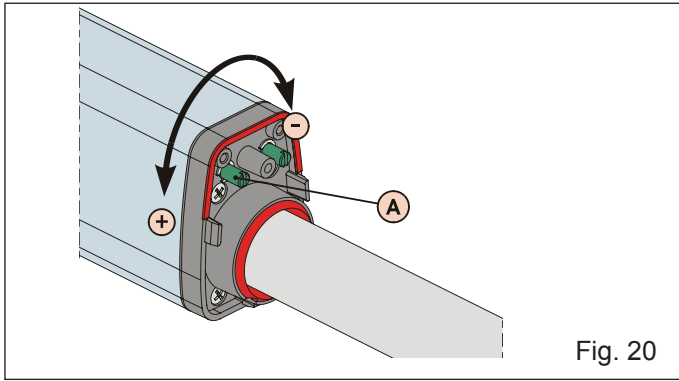

Fig. 20

5. Reposition the cap (Fig. 18 Ref. B) and tighten the fastening screw (Fig. 18 Ref. A).

#### 4.7. Start-up

**ATTENTION: Cut power before performing any work on the system or operator.**

Carefully observe the GENERAL SAFETY RULES.

Following the indications in Fig. 3, lay the proper cable conduits and make the electrical connections of the control board and chosen accessories.

1. Power up the system and determine the status of the LEDs (as shown in the table of the control board instructions).
2. Program the control board according to your needs by following the control board instructions.
3. Test the system, carefully checking the operating efficiency of the motor and of all the accessories connected to it, paying special attention to the safety devices

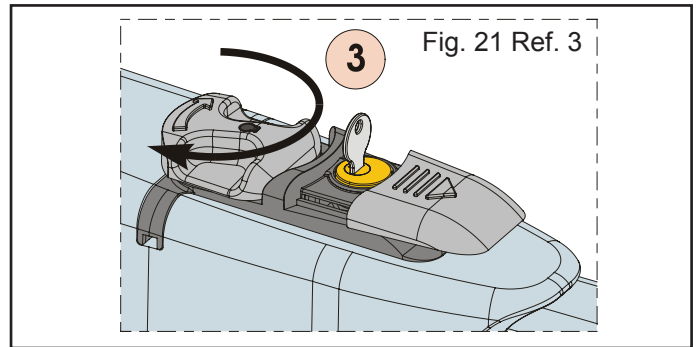
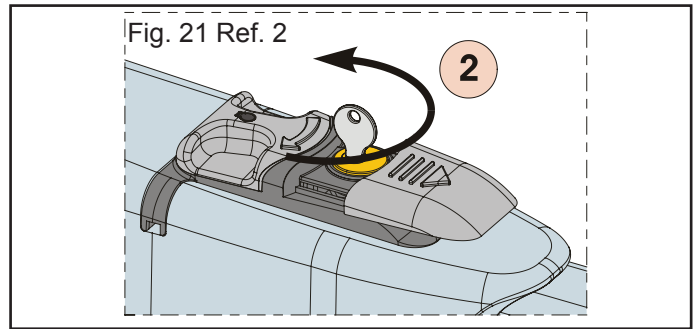

Note: To keep the operator in manual operation, the control lever should be left in its current position (turned 180°) and power should be cut to the system.

#### Restoring Normal Operation

To restore normal operating conditions, proceed as follows:

1. Turn the release system's control lever 180° in the opposite direction of the arrow.
2. Turn the release key 90° and remove it.
3. Close the protection cover.
4. Power up the system and perform a complete cycle of movement to check that the automated system is correctly restored.

### 5. MANUAL OPERATION

If the gate system needs to be moved manually due to lack of power or to an operator malfunction, proceed as follows:

1. Cut power by means of the safety circuit breaker (even in the event of a power outage).
2. Slide the protective cap, Fig. 21, Ref. 1.
3. Insert the key and turn it 90°, Fig. 21, Ref. 2.
4. To release the operator, turn the control lever 180° in the direction indicated by the arrow on the release system, Fig. 21, Ref. 3.
5. Open and close the leaf manually.

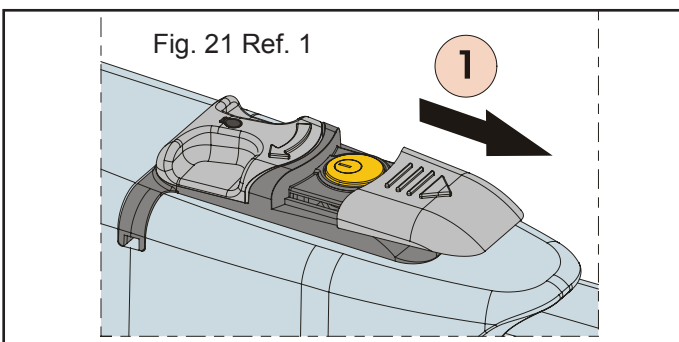

### 6. MAINTENANCE

To ensure safety and trouble-free operation, an overall check of the system should be carried out every 6 months.

### 7. REPAIRS

For any repairs, contact an authorized FAAC repair center.

8. 415 L LS PARTS DIAGRAM

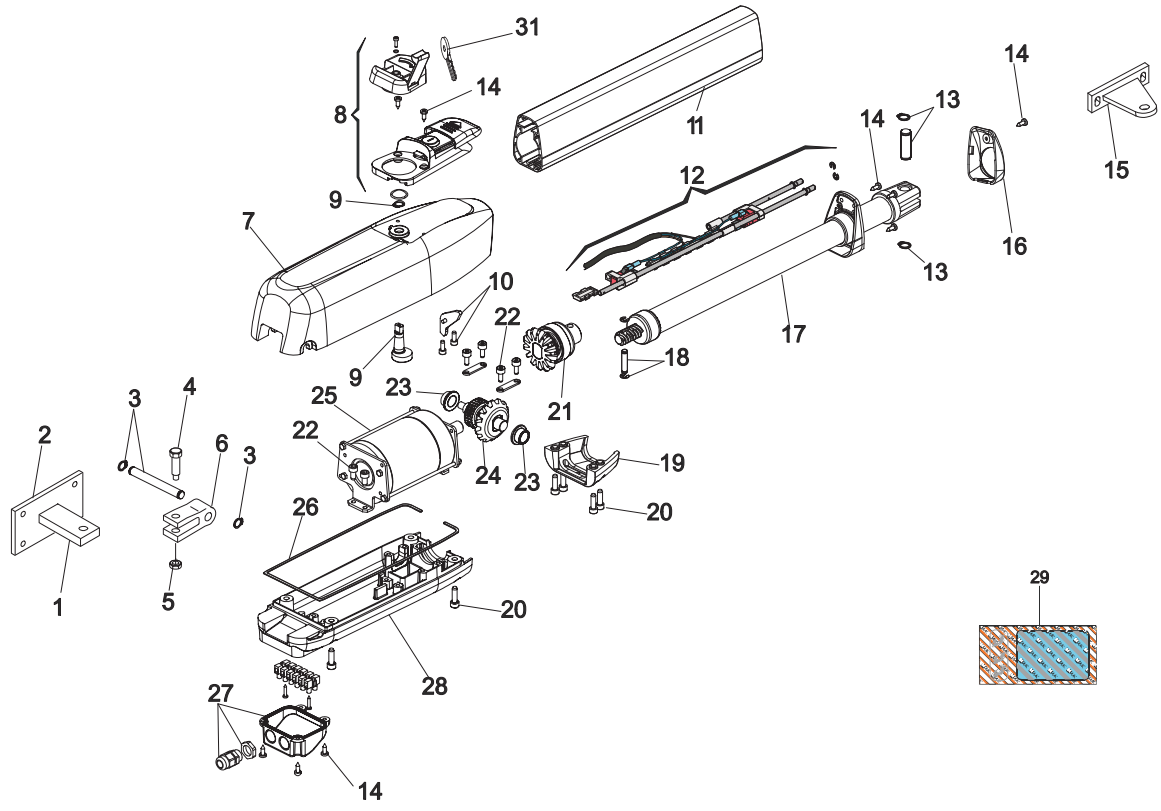

POS.	P/N	DESCRIPTION
01	72200165	REAR MOUNTING BRACKET
02	72840065	REAR MOUNTING PLATE
03	718366	LONG PIN
04	7182075	SHORT PIN
05	N/A	HEX NUT
06	7221115	REAR FORK
07	716148	UPPER BODY
08	428403	MANUAL RELEASE ASSEMBLY
09	60202145	MANUAL RELEASE CAM
10	60202155	MANUAL RELEASE LEVER
11	716151	PROTECTIVE COVER
12	490108	LIMIT SWITCH ASSEMBLY
13	718354	FRONT PIN WITH SEEGER
14	N/A	4.2X13mm SELF TAPPING SCREW
15	728271	FRONT MOUNTING BRACKET
16	711027	LIMIT SWITCH ADJUSTERS COVER
17	490104	CYLINDER

POS.	P/N	DESCRIPTION
18	718367	SCREW DRIVE PIN WITH SEEGER
19	499399	LOCKING LOWER FLANGE
20	N/A	6.3X19mm SELF TAPPING SCREW
21	60202225	GEAR (piston)
22	N/A	4.8X13mm SELF TAPPING SCREW
23	60202165	BUSHING
24	60202215	GEAR (motor)
25	60202205	24V MOTOR
26	709324	GASKET
27	60202175	ELECTRIC CABLE COVER
28	716149	LOWER HALF BODY
29	490106	415 LS SKIN PACK
31	7120885	LOCK KEY

**1. E024U CONTROL BOARD DESCRIPTION & CHARACTERISTICS**

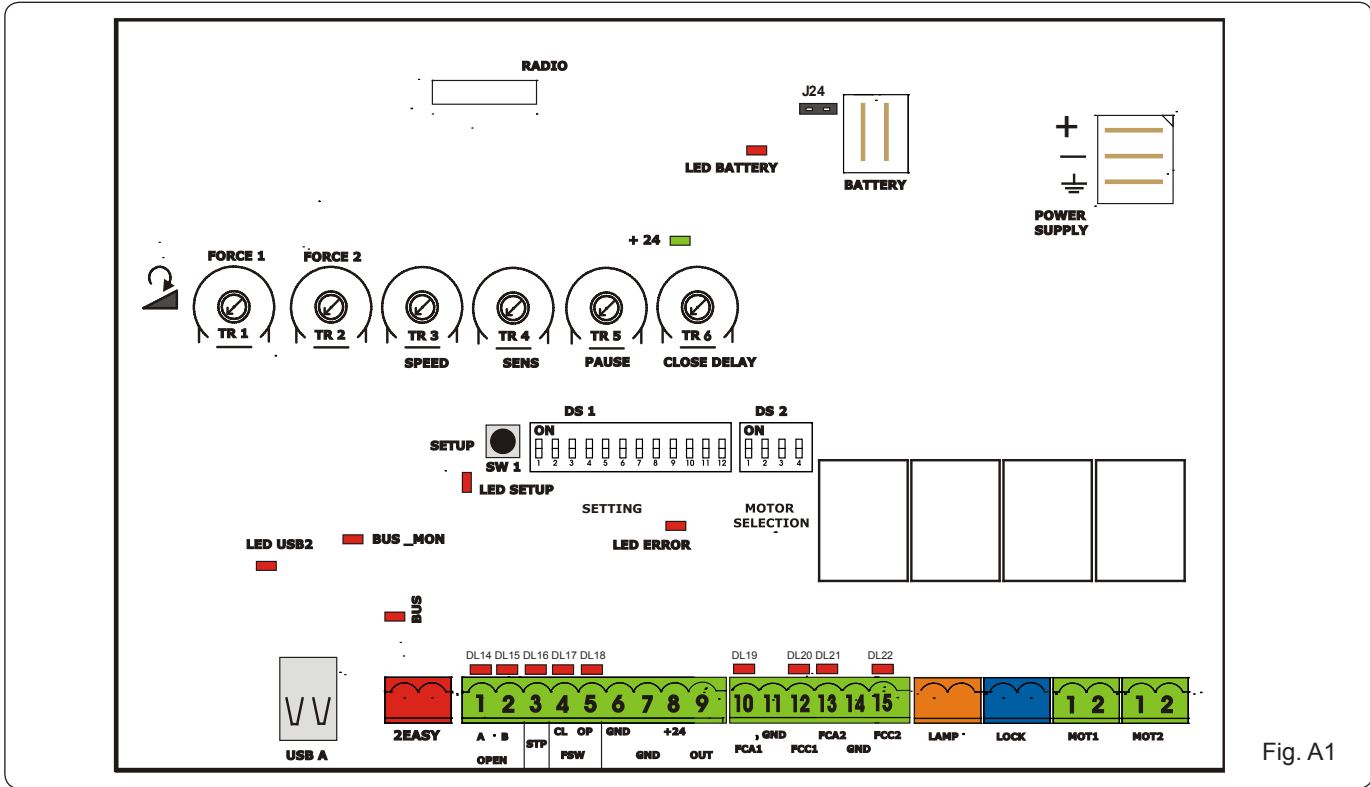

Fig. A1

**1.1 TECHNICAL SPECIFICATIONS**

Main power supply	115/230 V~ 50/60 Hz switchable
Secondary power supply	24 Vdc - 16 A max. (min. 20 Vdc. - max. 36 Vdc.)
Power consumption	stand-by = 4W max. = 400 W
Max load per motor	7 A
Accessory power supply	24 Vdc - 500 mA
Battery charge current	150 mA
Operating temperature	-4 °F.....+131 °F
Protection fuses	All self-resetting
Main power fuse	2.5 A
Operating Logics	E, A, S, EP, AP, SP, B, C
Operating time out	10 min.
Pause time	Programmable (0 to 4 min) with trimmer
Motor force, speed, obstacle sensitivity, closing delay	Programmable with dedicated trimmer
Connector inputs	Power supply, Battery, Radio receiver, USB
Terminal strip inputs	Encoder, Open A, OpenB, Stop, Open safety fotocell, Closing safety fotocell, Limit switches
Terminal strip outputs	Lamp, Buzzer, Motors, Lock, Programmable OUT, accessory power supply
Programming	With trimmers, dipswitches and pushbutton

**1.2 LAYOUT AND COMPONENTS**

RADIO	Connector for the radio receiver
BATTERY	Connector for the backup battery
J24	Jumper to disable battery charging (With the jumper present the battery is charged)
POWER SUPPLY	DC Power supply input
TR1 to TR6	Programming Trimmers
+24 LED	DC power indicator
SW1 - SETUP	Pushbutton for automatic setup
DS1 - DS2	Programming dipswitches
LED ERROR	Troubleshooting indicator
USB A	USB connection for software upgrade

**1.3 RADIO CONNECTION**

On the radio connector it's possible to plug in receivers RP and RP2. With a single channel radio RP it will be possible to activate only the OPEN A input, with a dual channel radio RP2 it will be possible to activate both OPEN A and OPEN B inputs. Plug in the radio board with the component side towards the internal part of the board.



Make sure you insert or disconnect the board ONLY with the power off.

2. INPUT / OUTPUT DESCRIPTION

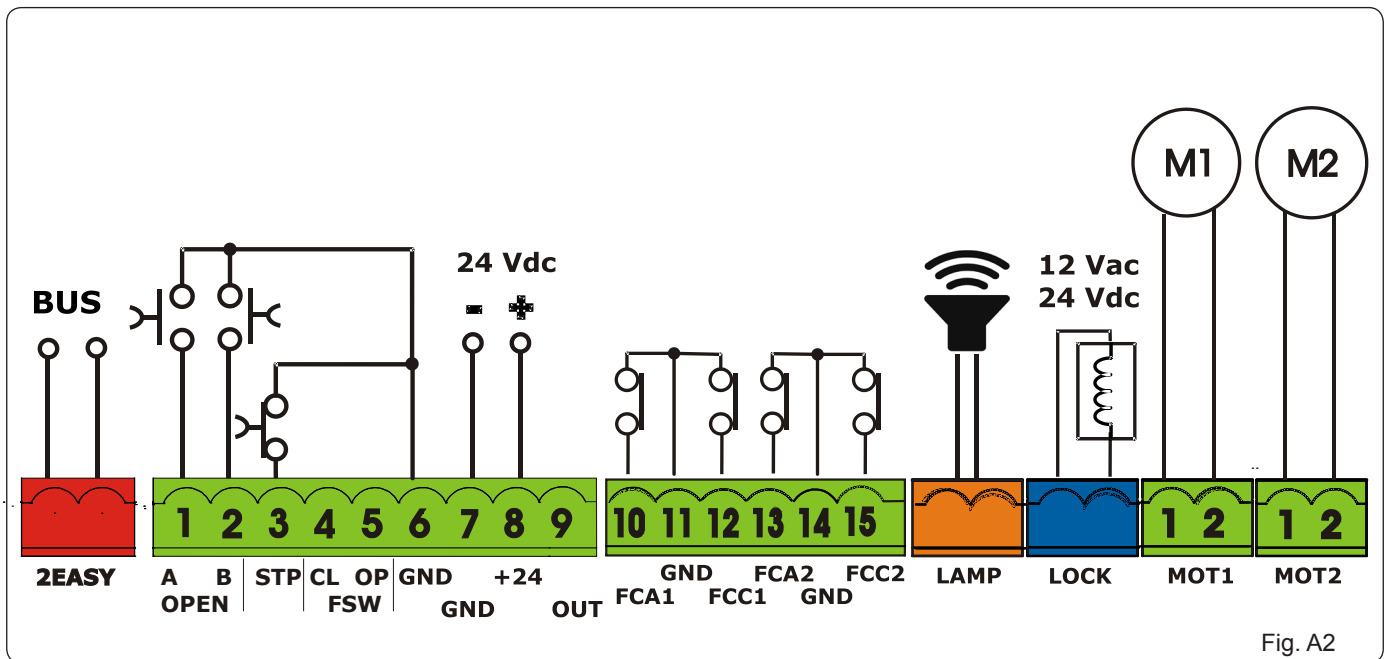

Fig. A2

PIN	LABEL	FUNCTION
2 EASY	2 EASY	Input for bus 2easy accessories (encoder)
1	OPEN A	N.O. Contact for total opening command
2	OPEN B / CLOSE	OPEN B: N.O. Contact for opening of leaf 1 only (with only one leaf the opening stops at 50% of traveling) CLOSE (LOGIC B-C): N.O. Contact for closing command
3	STOP	N.C. Contact for stop command
4	FSW CL	N.C. Contact for closing safety
5	FSW OP	N.C. Contact for opening safety
6	GND (-)	24 Vdc negative
7	GND (-)	24 Vdc negative
8	+ 24	24 Vdc positive
9	OUT (-)	Programmable output (See: DS1 SW 11-12)
10	FCA 1	Open limit switch Motor 1
11	GND (-)	24 Vdc negative
12	FCC 1	Close limit switch Motor 1
13	FCA 2	Open limit switch Motor 2
14	GND (-)	24 Vdc negative
15	FCC2	Close limit switch Motor 2
LAMP	LAMP	Audio alarm output (DS1 SW11=OFF) Output for flashing light 24Vdc 15W max (DS1 SW11=ON)
LOCK	LOCK	Output for electrical lock, max 5A pulse (DS2 - SW 4=OFF) 12 Vac / 24Vdc Always ON (maglock): max 1 A (DS2 - SW 4=ON) 24 Vdc
MOT1	MOT 1	Motor 1 output ( first moving motor )
MOT2	MOT 2	Motor 2 output ( second moving motor )
USB A	USB	Firmware upgrade input

### 3. PHOTOCELLS CONNECTIONS

How to connect Normally Open contacts.  
(Connect them in parallel)

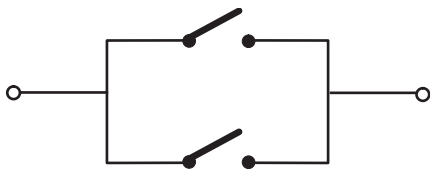

Fig. A3

How to connect Normally Close contacts.  
(Connect them in series)



Fig. A4

The E024U board allows the connection of several safety devices (for example photocells). With photocells you can activate the FAILSAFE function, which, before each movement of the operator, tests each photocell. In case the test fails the movement is inhibited. To activate this function set to ON the dip-switch N. 11 and 12 of DS1, and connect the negative of the transmitter to the OUT pin (No.9).

The photocells must be connected depending on which area they must protect. (See Fig. A5)

**Closing Safety D** : These photocells protect the area covered by the gate during the closing movement. They have no effect during the opening movement.

**Opening Safety B-C** : These photocells protect the area covered by the gate during the opening movement. They have no effect during the closing movement.

**Opening/Closing Safety A** : These photocells protect the area covered by the gate both during the opening and the closing movements.

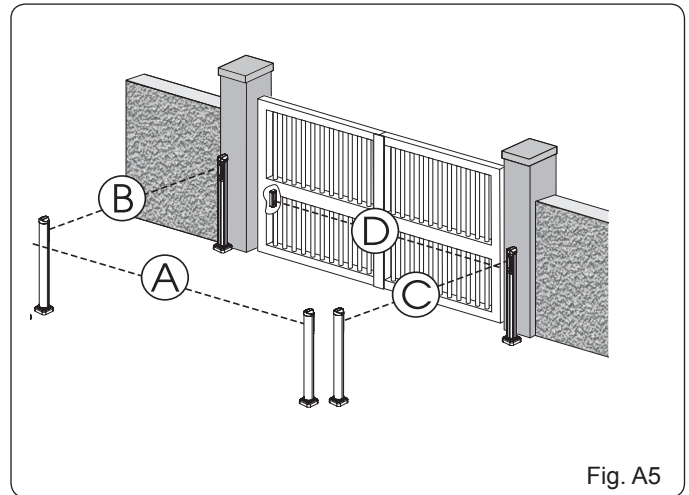

Fig. A5

#### 3.1 CONNECTIONS TO NORMALLY CLOSE (N.C.) PHOTOCELLS

Connection of a pair of closing photocells and a pair of opening/closing photocells

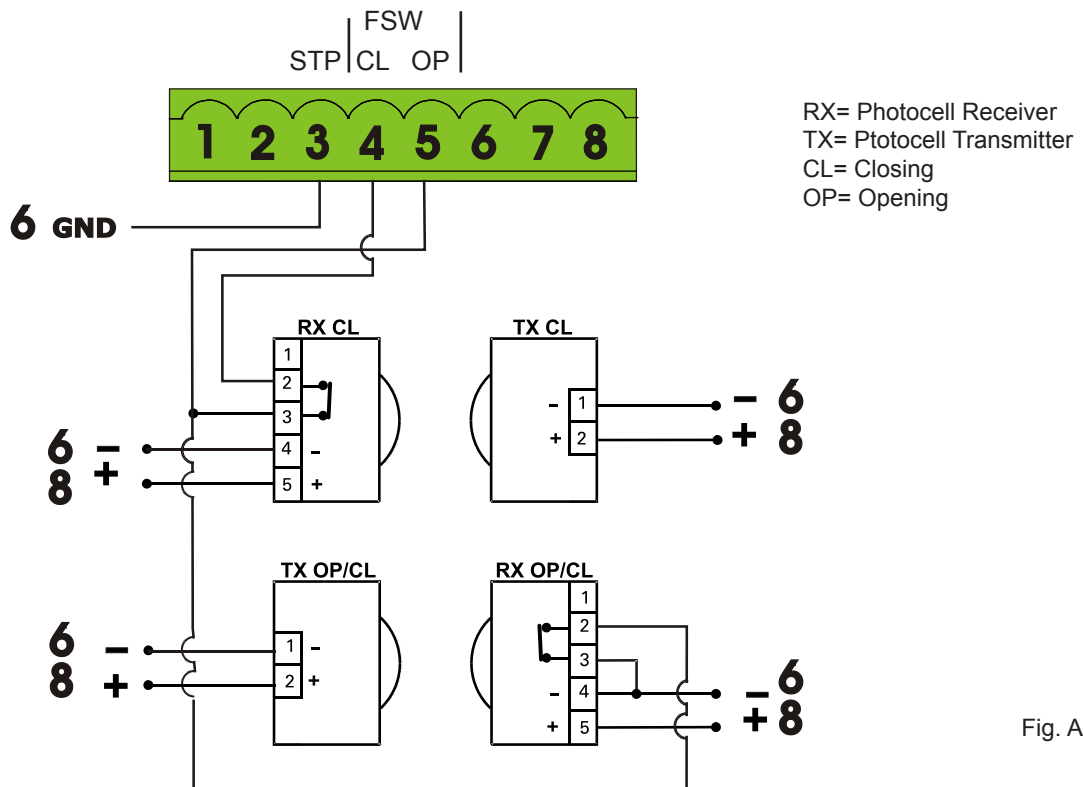
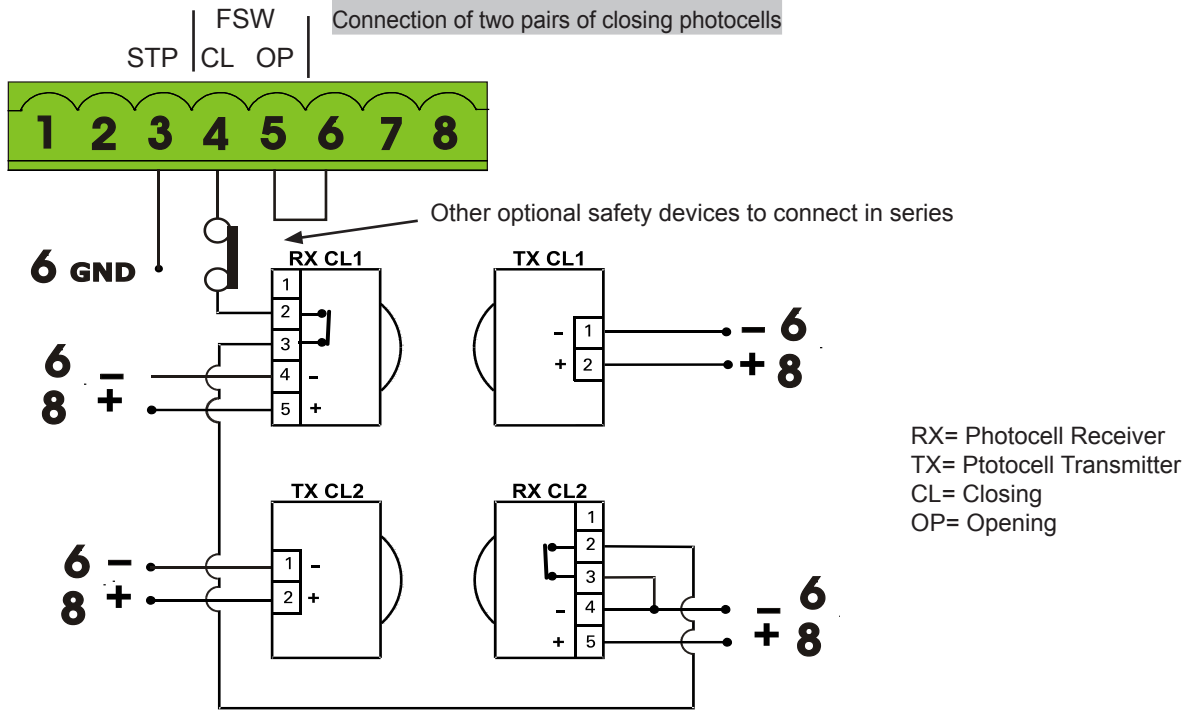

Fig. A6

To use the FAIL-SAFE mode connect the negative power supply of the transmitters to OUT (pin 9), and set dip-switch 11 and 12 to ON on DS1



To use the FAIL-SAFE mode connect the negative power supply of the transmitters to OUT (pin 9), and set dip-switch 11 and 12 to ON on DS1

When using the FAIL-SAFE mode also the safety inputs not used (FSW CL , FSW OP) must be connected to OUT (pin No. 9)

Fig. A7

Connection of a pair of closing photocells, a pair of opening photocells and a pair of opening/closing photocells

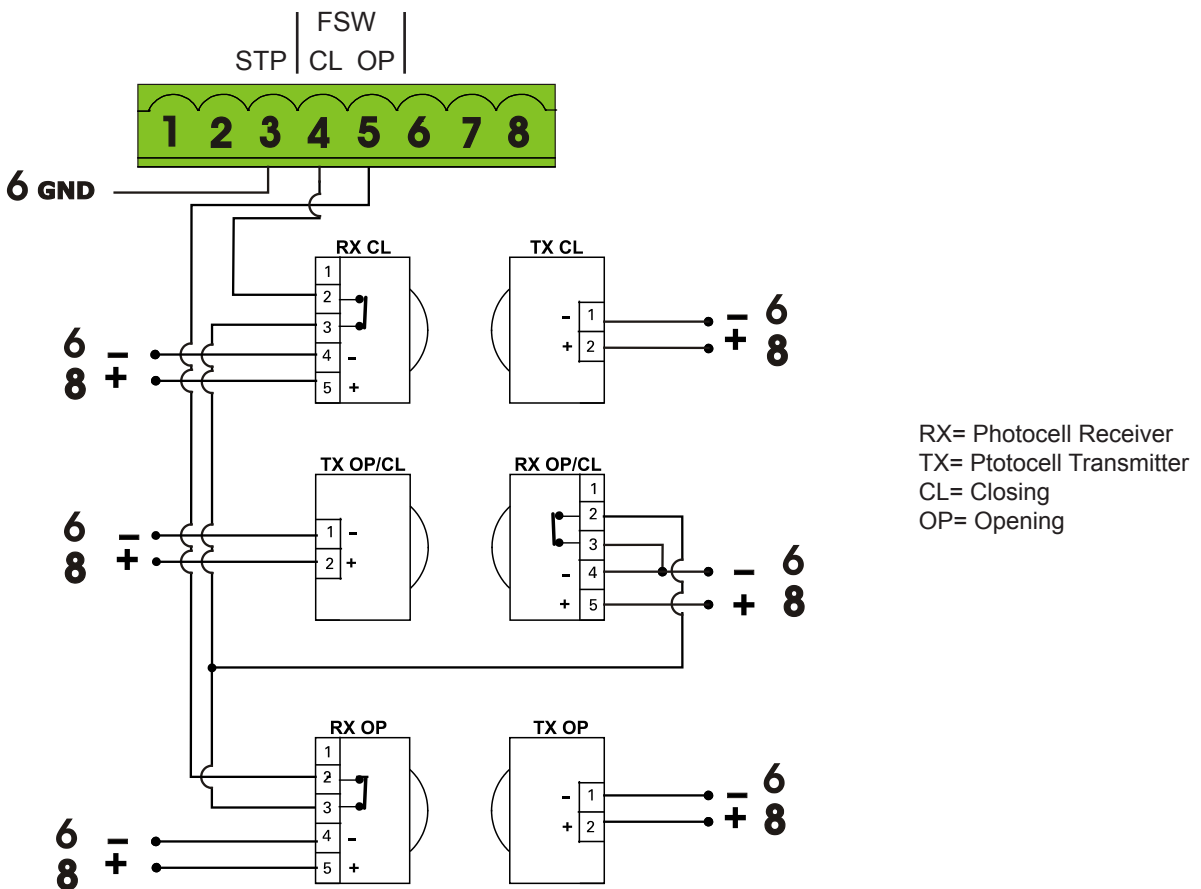

To use the FAIL-SAFE mode connect the negative power supply of the transmitters to OUT (pin 9), and set dip-switch 11 and 12 to ON on DS1

Fig. A8



Connection of a pair of closing photocells and a pair of opening photocells

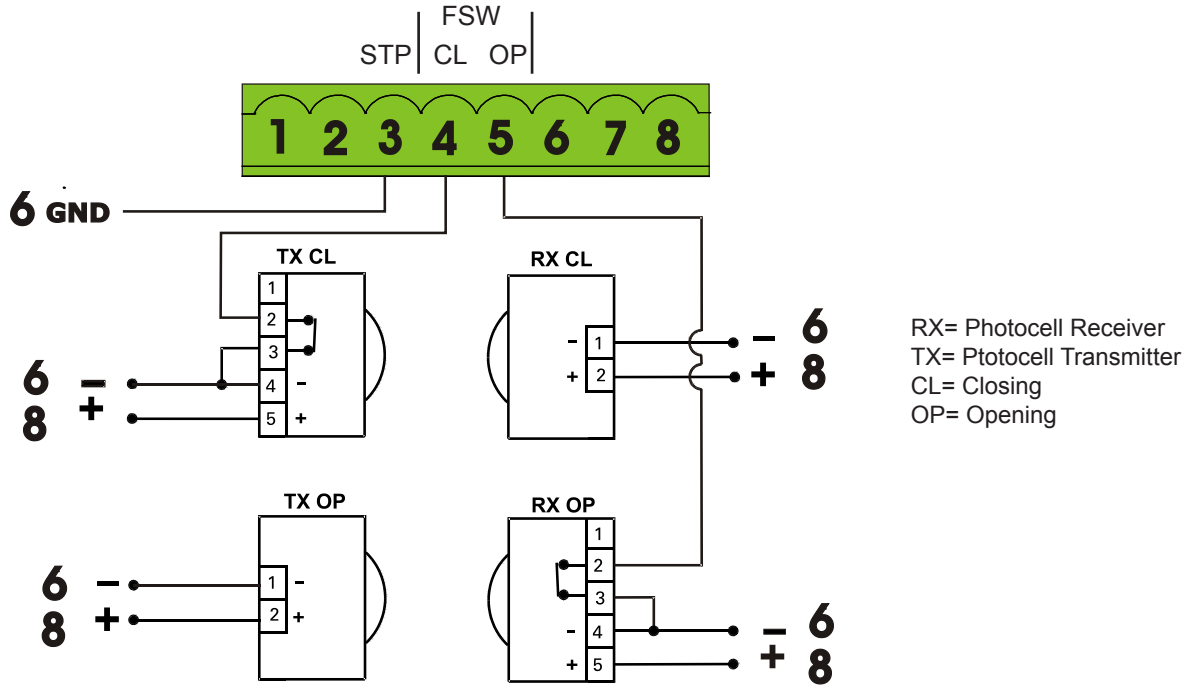

To use the FAIL-SAFE mode connect the negative power supply of the transmitters to OUT (pin 9), and set dip-switch 11 and 12 to ON on DS1

Fig. A9

Connection of no safety or stop devices  
(NOT RECOMMENDED)

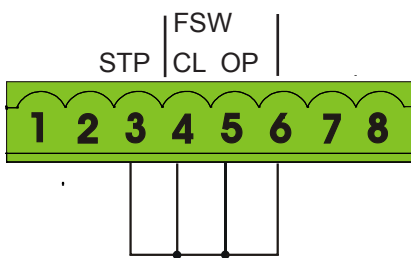

Fig. A10

Connection of a generic closing safety device and a generic open safety device

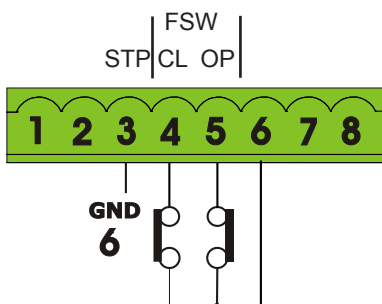
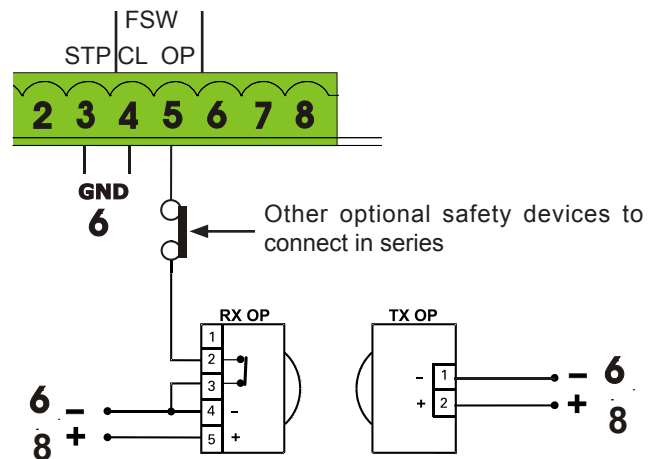

Fig. A11

Connection of one pair of opening photocells



To use the FAIL-SAFE mode connect the negative power supply of the transmitters to OUT (pin 9), and set dip-switch 11 and 12 to ON on DS1

When using the FAIL-SAFE mode also the safety inputs not used (FSW CL , FSW OP) must be connected to OUT (pin No. 9)

Fig. A12

**4. PROGRAMMING**

**4.1 DIP SWITCH DS1 SETTINGS FOR OPERATING LOGIC**

OPERATING LOGIC

DS 1: SW 1 - SW 2 - SW 3

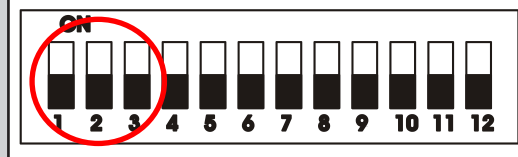

LOGIC	SW 1	SW 2	SW 3	PAUSE TIME	DESCRIPTION
E (default) Semiautomatic	OFF	OFF	OFF	NO	One command opens, the next one closes. A command during opening stops the gate
A Automatic	ON	ON	ON	0 - 4 min	One command opens, waits for the pause time and then closes automatically
S Security	OFF	OFF	ON	0-4 min	One command opens, waits for the pause time and then closes automatically. If the closing safety is activated or another command is given during the pause time it closes
EP Semiautomatic step by step	OFF	ON	OFF	NO	One command opens, the next one closes. During the movement a command stops the gate
AP Automatic step by step	OFF	ON	ON	0-4 min	One command opens, waits for the pause time and then closes automatically. A command during the pause time holds the gate open
SP Security step by step	ON	OFF	OFF	0-4 min	One command opens, waits for the pause time and then closes automatically. If the closing safety is activated during pause time the gate closes in 5 s. A command during pause time holds open the gate
B Manned Pulsed	ON	OFF	ON	NO	An open A command opens the gate, an open B command closes the gate
C Manned Constant	ON	ON	OFF	NO	Holding open A active opens the gate, holding Open B active closes the gate



For more details on the operating logics please refer to Chapter 12 - Function Logics

4.2 ADJUSTING TRIMMERS

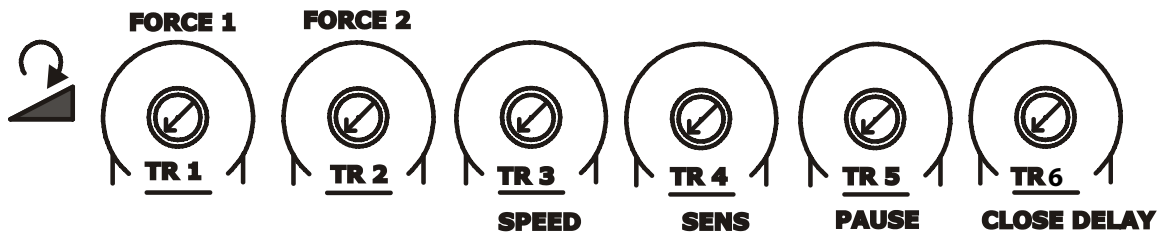

**TR1** – FORCE ADJUSTMENT MOTOR 1  
Turn clockwise to increase the opening and closing force

**TR 2** – FORCE ADJUSTMENT MOTOR 2  
Turn clockwise to increase the opening and closing force

**TR 3** – SPEED ADJUSTMENT FOR MOTOR1 AND MOTOR 2  
Turn clockwise to increase the opening and closing speed

**TR 4** – SENSITIVITY ADJUSTMENT FOR OBSTACLE DETECTION FOR MOTOR 1 AND MOTOR 2  
Turn clockwise to increase the sensitivity for obstacle detection.

With this trimmer you can adjust the reaction time for the board to invert the motion of the gate in case of obstacle detection, or the complete stop in case the board is in the positive stop detection zone. If an obstacle is detected during the gate movement the board will invert the motor rotation until the gate goes back to the original starting position. If in the successive movement an obstacle is detected again the board will be put in alarm mode and won't take any more commands until the STOP input is activated (Alarm Reset) or power is cycled

**TR 5** – PAUSE TIME ADJUSTMENT ( 0 - 4 min. )  
Turn clockwise to increase the pause time.

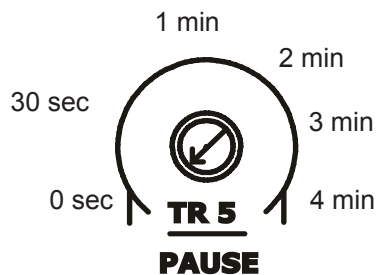

 Dip switches DS1: 1 to 3 need to be set for an operating mode with PAUSE time for this adjustment to have any effect

**TR6** - CLOSING DELAY OF LEAF 1 OVER LEAF 2 ADJUSTMENT ( 0 - 15 sec )  
Turn clockwise to increase the delay

4.3 DIP SWITCH DS1 SETTINGS FOR BOARD SETUP

BOARD SETUP		DS 1: SW 4 to SW 12
<b>OPENING DELAY</b>	SW 4	The opening of leaf 2 is delayed after the opening of leaf 1. This is to avoid that the gate's leafs interfere with each other during the initial part of the movement. In case there is only one leaf it has no effect.
0 sec (default)	OFF	
2 sec	ON	
<b>REVERSE AND LAST STROKE</b>	SW 5	If active, before opening, while the gate is closed, the motors thrust to close for 2 s to facilitate the release of the electric lock. At closing the motors are activated for a final stroke after slowdown to facilitate locking of the electric lock.
inactive (default)	OFF	
active	ON	
<b>MAX THRUST AT STARTUP</b>	SW 6	With this function active the motors work at maximum force at startup (regardless of the force setting) during the initial phase of the movement. Useful for heavy leafs
inactive (default)	OFF	
active for 3 sec	ON	
<b>AUTOMATIC OPENING IN CASE OF POWER FAILURE</b>	SW 7	If active and with the optional backup battery installed, the board will open the gate after one minute from the power failure and keep it open. Within the minute wait it's always possible to open and close the gate with a command. If the logic used has a pause time the board will close the gate when the power comes back.
inactive (default)	OFF	
active	ON	
<b>CLOSING SAFETY LOGIC</b>	SW 8	With this function you can choose the behaviour of the closing safety. With SW8 OFF the gate movement will be reversed as soon as the safety is active, with SW8 ON the gate will stop when the safety is active and it will reverse only when the safety is deactivated again.
immediate reverse (default)	OFF	
reverse when cleared	ON	
<b>PREFLASHING</b>	SW 9	This function activates the flashing lamp for 5s before the movement of the gate
inactive (default)	OFF	
active for 5 sec	ON	
<b>EXTRA SENSITIVITY TO OBSTACLE DETECTION</b>	SW 10	If active this function allows to have an immediate reverse in case the gate hits a rigid obstacle, while keeping the motor active in case of a gradual increment of resistance, like with wind pressure on the gate or increased friction
inactive (default)	OFF	
active	ON	
<b>ORANGE TERMINAL FUNCTION</b>	SW 11	If OFF after the second consecutive obstacle detection this output is activated until the STOP contact is open or the power is cycled if ON the output can be connected to a warning lamp. NOTE: for UL325 compliance this switch must be left OFF
Audio Alarm (default)	OFF	
Warning Lamp	ON	
<b>OUT FUNCTION (pin 9)</b> max 100mA	SW 12	if OFF: use pin 9 as power supply negative for a warning lamp. The lamp will be active during opening, pause and stop. Flashing during close, off when the gate is closed If ON: use pin 9 as power supply negative for the safety photocells. Before any movement the board will check for the presence of the safety photocells. If the test fails the gate will not move.
Lamp	OFF	
Photocells FAIL SAFE active	ON	

4.4 DIP SWITCH DS2 SETTINGS FOR OPERATOR TYPE AND LOCK MODE

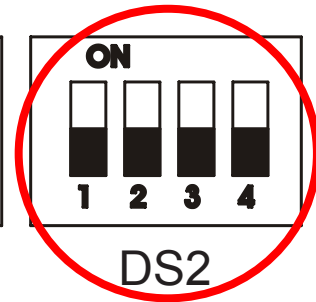
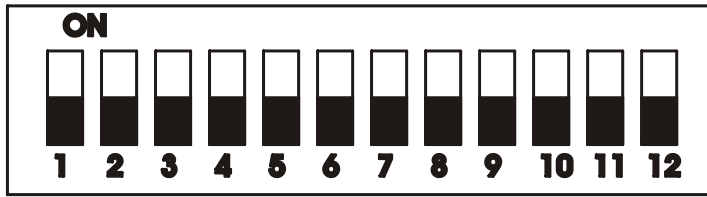

**IMPORTANT**



DS 2			
OPERATOR SELECTION			
OPERATOR TYPE	SW 1	SW 2	SW 3
S450H, S800H	OFF	OFF	OFF
S418	OFF	OFF	ON
412, 413, 415, 390, 770	ON	OFF	OFF
391	OFF	ON	OFF
NON FAAC	ON	OFF	ON

DS 2	
LOCK OUTPUT MODE	
OUTPUT MODE	SW 4
Active only for 3 sec. after an open impulse (from gate closed)	OFF
Active always except 3 sec. before an opening	ON

5. LED DIAGNOSTICS

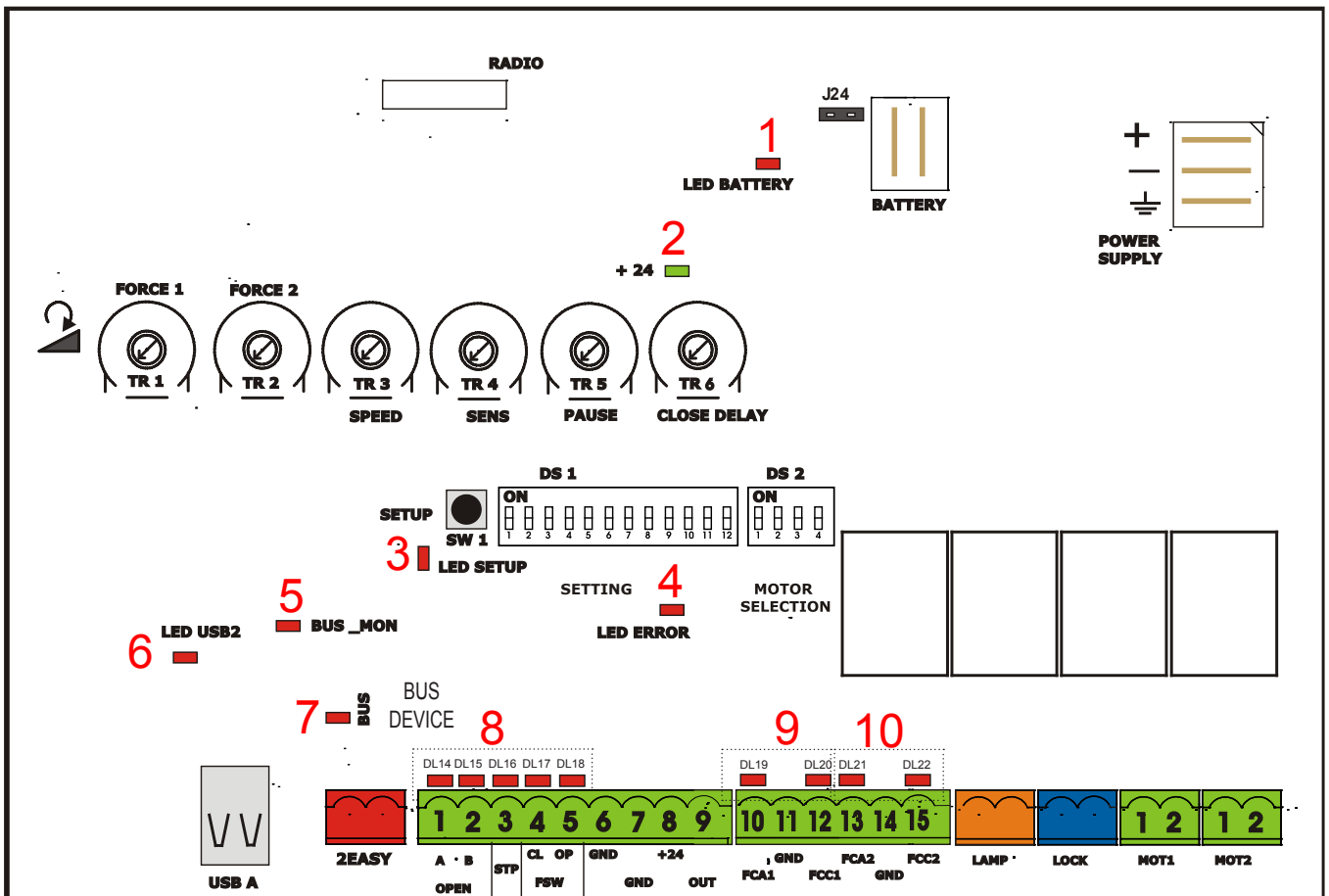

L E D	DESCRIPTION	LED STATUS		
		In BOLD the normal state with gate closed and working		
		ON STEADY	OFF	BLINKING
<b>1</b>	LED BATTERY	Board working on AC power	Board working on battery power or ext supply	Battery charging
<b>2</b>	LED +24	<b>Main power present</b>	Main power OFF	
<b>3</b>	LED SET-UP		<b>Normal operation</b>	SLOW BLINK (1 sec. ON - 1 sec. OFF) SET-UP needed
				FAST BLINK (0.5 sec. ON - 0.5 sec OFF) SET UP in in progress
<b>4</b>	LED ERROR	Board malfunction	<b>No errors</b>	Error conditions. See LED ERROR DISPLAY table
<b>5</b>	LED BUS_MON	<b>Communication on Bus "2easy" OK</b>	Communication bus "2Easy" inactive. Verify the bus "2Easy" devices for shorts	Bus 2Easy devices with the Same address. Verify dip switch Setting on photocells or Encoder LEDs
<b>6</b>	LED USB		<b>Software update done or USB key not present</b>	USB key inserted and software Update in progress (DON'T Remove the USB key)
<b>7</b>	RESERVED			
<b>8</b>	LED DL 14 OPEN A INPUT (N.O.)	OPEN A active	<b>OPEN A not active</b>	
	LED DL 15 OPEN B INPUT (N.O.)	OPEN B active	<b>OPEN B not active</b>	
	LED DL 16 STOP INPUT (N.C.)	<b>STOP non active</b>	STOP active or wiring error	
	LED DL 17 FSW CL INPUT (N.C.)	<b>Closing safety devices clear</b>	Closing safety devices triggered or wiring error	
	LED DL 18 FSW OP INPUT (N.C.)	<b>Opening safety devices clear</b>	Opening safety devices triggered or wiring error	
<b>9</b>	LED DL 19 FCA1 OPEN LIMIT SWITCH MOTOR1 (N.C.)	<b>Limit switch OFF or not used</b>	Limit Switch activated	
	LED DL 20 FCC1 CLOSE LIMIT SWITCH MOTOR1 (N.C.)	Limit switch OFF or not used	<b>Limit Switch activated</b>	
<b>10</b>	LED DL 21 FCA2 OPEN LIMIT SWITCH MOTOR2 (N.C.)	<b>Limit switch OFF or not used</b>	Limit Switch activated	
	LED DL 22 FCC2 CLOSE LIMIT SWITCH MOTOR2 (N.C.)	Limit switch OFF or not used	<b>Limit Switch activated</b>	



The diagnostic LED shows only one error condition at a time, with the priority of the below table. In case there is more than one error once one is eliminated the LED will show the next

LED ERROR DISPLAY		
NUMBER OF FLASHES	ERROR CONDITION	SOLUTION
1	OBSTACLE DETECTION	Remove the obstacle
2	BOARD IN SLEEP MODE (Slow blinking means that the automatic open in case of power failure function is active)	Verify the presence of AC power
3	MOTOR 1 FAILURE	Replace motor 1
4	MOTOR 2 FAILURE	Replace motor 2
5	ENCODER on motor 1 or motor 2 broken or wiring error	Verify the encoder wiring and LED status. If they are correct replace the encoder
6	FAIL SAFE FAILED	Verify the photocells wiring and alignment
7	BOARD THERMAL PROTECTION ACTIVE	Turn off the board and wait until the components cool down
8	MAX RUN TIME REACHED WITHOUT FINDING THE POSITIVE STOP (10 min. )	- Verify that the operator manual release is not engaged - Verify that the board recognizes the mechanical stop, in case redo the setup procedure

**6. TIME LEARNING (SET-UP)**

After powering up the board for the first time or when the board will need it the setup LED will blink at a slow frequency to indicate that the setup procedure to learn the running times is needed.

The setup can be redone at any time by pressing and holding the setup button as indicated below.

After the setup first movement, if the leafs are opening instead of closing you need to reverse the wires going to the motor that moves in the wrong direction

- When they reach the close mechanical stop or FCC1 and FCC2 both leafs stop and leaf 1 restarts automatically opening at full speed followed by leaf 2 (if present).
- If you selected an automatic logic the board will wait for the pause time and then closes the gate automatically. Otherwise you have to give an OPEN command to close the gate.

**6.1 AUTOMATIC TIME LEARNING**

WARNING: If the time learning setup is done automatically then the slow down points are set by the board on his own

Move the leafs to the mid position  
Very important for a good result

- Press and hold the SETUP button until the SETUP LED lights up, wait about 3 sec. until it turns off and then release it immediately. NOTE: If you wait too long to release it the manual set-up will start. The LED will blink during the setup procedure
- Leaf 2 (if present) starts to move slowly in closing direction, stopping when it reaches the mechanical stop or FCC2.
- Leaf 1 begins to move slowly in closing direction, stopping when it reaches the mechanical stop, or FCC1.
- Leaf 1 starts to move slowly in opening direction, followed by leaf 2 (if present) still slowly.
- When they both reach the open mechanical stop or FCA1 and FCA2 they stop and reverse, leaf 2 (if present) automatically starts closing at full speed followed by leaf 1.

**6.2 MANUAL TIME LEARNING**

WARNING: If the manual time learning setup is done then the slow down points must be set by the installer during the procedure

Move the leafs to the mid position  
Very important for a good result

- Press and hold the SETUP button until the SETUP LED lights up, keep it pressed for about 3 sec. until it turns off and keep it pressed more until the leaf 2 (if present) starts moving slowly. The LED will blink during the setup procedure
- Leaf 2 will move in closing direction until it reaches the mechanical stop or FCC2
- Leaf 1 starts moving slowly until it reaches the mechanical stop or FCC1
- Leaf 1 starts moving in opening direction at the set speed (trimmer speed).
- At the point where you want the slowdown to start give an OPEN A command with the push button or the remote that is already stored in memory. Leaf 1 starts to slow down and stops when it reaches the mechanical stop or FCA1.
- Leaf 2 starts moving in opening direction at the set speed (trimmer speed)

7. At the point where you want the slowdown to start give an OPEN A command with the push button or the remote that is already stored in memory. Leaf 2 starts to slow down and stops when it reaches the mechanical stop or FCA2.
8. Leaf 2 starts to close at the set speed (trimmer speed).
9. At the point where you want the slowdown to start give an OPEN A command with the push button or the remote that is already stored in memory. The leaf 2 starts to slow down and stops when it reaches the mechanical stop or FCC2.
10. Leaf 1 starts to close at the set speed (trimmer speed).
11. At the point where you want the slowdown to start give an OPEN A command with the push button or the remote that is already stored in memory. Leaf 1 starts to slow down and stops when it reaches the mechanical stop or FCC1.
12. The manual time learning procedure is complete.

### 6.3 OBSTACLE DETECTION FUNCTION

The obstacle detection function is achieved by controlling the current absorption and / or through the encoder connected to the motors.

If the gate encounters an obstacle during the movement of opening or closing, the obstacle detection function is activated and the operator reverses the direction of the gate.

In case of a second consecutive obstacle the operator stops the gate right away and any further command is inhibited. To re-enable the automation, you must remove power or open the STOP contact input. Until this "reset" the Audio Alarm output will be active.

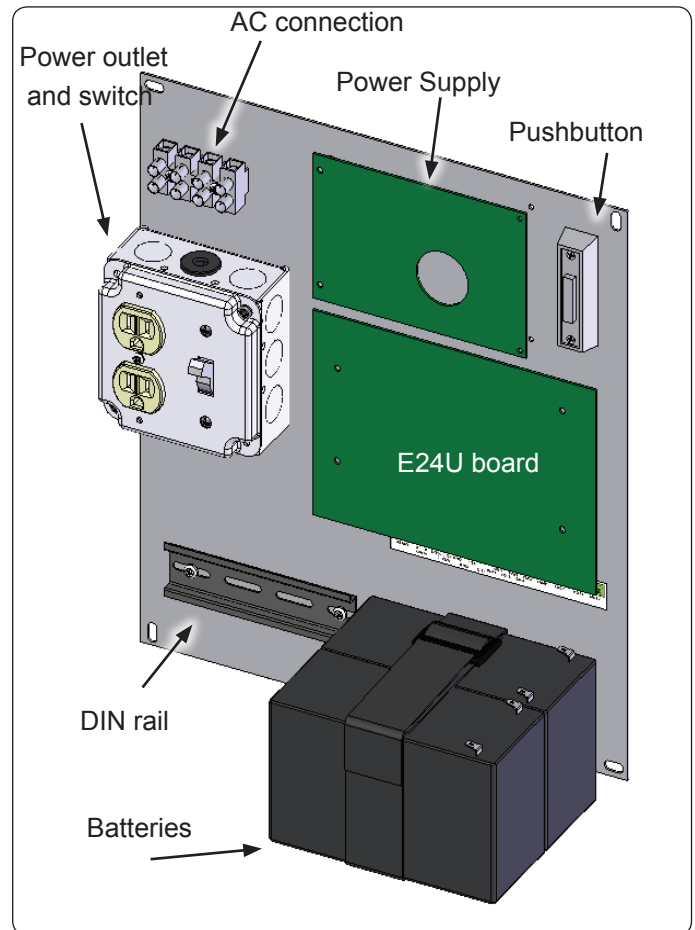

On the back panel are installed the control board, the power supply and additional accessories.

## 7. ENCLOSURE

The E024U board is supplied on a panel that fits in a 16x14" enclosure.

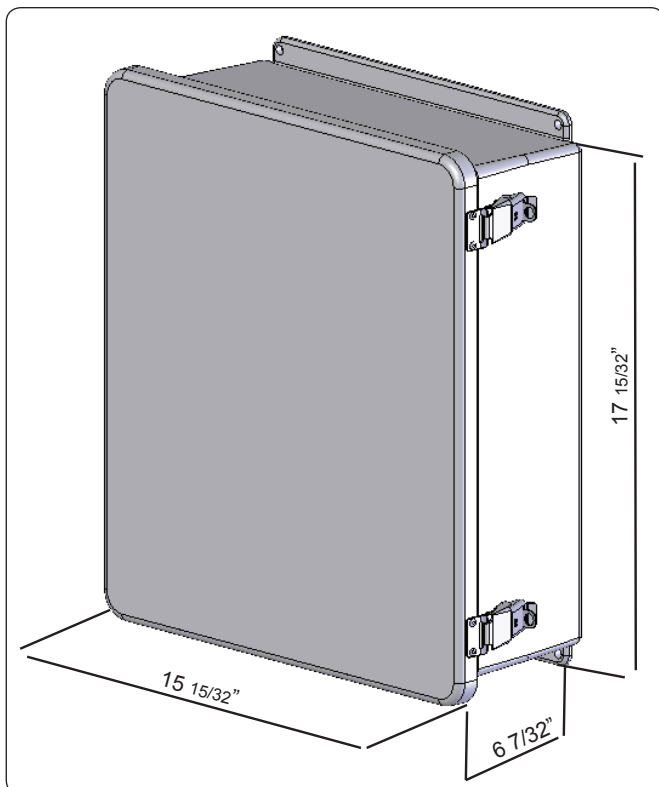

E024U CONTROL BOARD

## 8. POWER CONNECTION

### AC POWER GUIDELINES:

THE E024U control board and power supply uses a single phase AC power line to operate, charge the batteries, and power gate accessories. Use the following guidelines when installing the AC power:

1. Check the local wiring codes in all cases and follow all local building codes. Wiring and hookup should be performed by a qualified electrician/installer only.
2. AC power should be supplied from a circuit breaker panel and must have its own dedicated circuit breaker. This supply must include a green ground conductor.
3. Use copper conductor wires with liquid tight flexible conduit UL listed for electric cable protection

**14 AWG, 600V, 80°C**  
**Terminal Block max Torque 2.1 Nm**

4. Properly ground the gate operator to minimize or prevent damage from power surges and/or lightning. Use a grounding rod if necessary. A surge suppressor is recommended for additional protection.





### 10. FIRMWARE UPGRADE

The E024U board keeps the operating firmware in a field programmable memory, it can be easily upgraded through the on board USB port

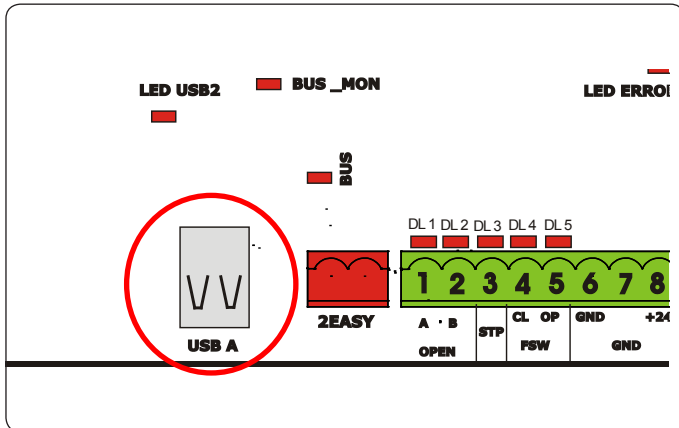

For the upgrade you need a USB Flash Drive, where you have to copy the file supplied by FAAC. Then follow these steps:

1. Disconnect the batteries if they are present.
2. Turn the AC power off and insert the Flash Drive into the USB A input on the board
3. Turn the AC power back on. The USB2 LED will start to flash to confirm the beginning of the software update. (WARNING: DON'T TURN THE POWER OFF OR REMOVE THE FLASH DRIVE UNTIL THE USB2 LED TURNS OFF.
4. Wait until the USB 2 LED turns off
5. Remove the USB Flash drive.
6. Cycle power, reconnect the batteries if needed and execute a new SETUP procedure (See chapter 6)



WARNING: Only upgrade the firmware with the proper file supplied by FAAC. otherwise the board could be damaged

### 11. FUNCTION LOGICS

LOGIC "E"	PULSES						
	OPEN A	OPEN B	CLOSE	STOP	FSW OP	FSW CL	FSW CL/OP
CLOSED	opens the leaves	opens leaf 1	no effect	no effect (OPEN disabled)	no effect (OPEN disabled)	no effect	no effect (OPEN disabled)
OPENING	stops operation (1)	stops operation	recloses leaves immediately	stops operation	immediately reverses at closing	no effect	stops and opens at release (OPEN stops - saves CLOSE)
OPEN	recloses leaves immediately (1)	recloses leaves immediately	recloses leaves immediately	no effect (OPEN/CLOSE disabled)	no effect	no effect (CLOSE disabled)	no effect (OPEN/CLOSE disabled)
CLOSING	reopens leaves immediately	reopens leaves immediately	no effect	stops operation	no effect	reverses at opening (see 2 <sup>nd</sup> level prog.)	stops and opens at release (OPEN stops - saves CLOSE)
BLOCKED	closes leaves	closes leaves	closes leaves	no effect (OPEN/CLOSE disabled)	no effect (OPEN disabled)	no effect (CLOSE disabled)	no effect (OPEN stops - saves CLOSE)

(1) if the cycle began with OPEN-B (leaf 1), both leaves are activated at opening

LOGIC "A"	PULSES						
	OPEN A	OPEN B	CLOSE	STOP	FSW OP	FSW CL	FSW CL/OP
CLOSED	opens and closes after pause time	opens leaf 1 and closes after pause time	no effect	no effect (OPEN disabled)	no effect (OPEN disabled)	no effect	no effect (OPEN disabled)
OPENING	no effect (1)	no effect	recloses leaves immediately	stops operation	reverses at closing	no effect	stops and opens at release (saves CLOSE)
OPEN IN PAUSE	reloads pause time (1)	reloads pause time of released leaf	recloses leaves immediately	stops operation	no effect	recharges pause time (CLOSE disabled)	recharges pause time (CLOSE disabled)
CLOSING	reopens leaves immediately	reopens leaves immediately	no effect	stops operation	no effect	reverses at opening (see 2 <sup>nd</sup> level prog.)	stops and opens at release (saves CLOSE)
BLOCKED	closes leaves	closes leaves	closes leaves	no effect (OPEN/CLOSE disabled)	no effect (OPEN disabled)	no effect (CLOSE disabled)	no effect (OPEN/CLOSE disabled)

(1) if the cycle began with OPEN-B (leaf 1), both leaves are activated at opening

LOGIC "S"	PULSES						
SYSTEM STATUS	OPEN A	OPEN B	CLOSE	STOP	FSW OP	FSW CL	FSW CL/OP
CLOSED	opens and closes after pause time	opens released leaf and closes after pause time	no effect	no effect (OPEN disabled)	no effect (OPEN disabled)	no effect	no effect (OPEN disabled)
OPENING	no effect (1)	no effect	recloses leaves immediately	stops operation	reverses at closure	continues to open and recloses immediately	stops and opens at release (saves CLOSE)
OPEN IN PAUSE	recloses leaves immediately (1)	recloses leaves immediately	recloses leaves immediately	stops operation	no effect	stops and, at release, closes	stops and, at release, closes
CLOSING	reopens leaves immediately	reopens leaves immediately	no effect	stops operation	no effect	reverses at opening (see DS1-SW8) and closes immediately at end	stops and opens after release and closes immediately at end
BLOCKED	closes leaves	closes leaves	closes leaves	no effect (OPEN/CLOSE disabled)	no effect (OPEN disabled)	no effect (CLOSE disabled)	no effect (OPEN/CLOSE disabled)

(1) if the cycle began with OPEN-B (leaf 1), both leaves are activated at opening

LOGIC "EP"	PULSES						
SYSTEM STATUS	OPEN A	OPEN B	CLOSE	STOP	FSW OP	FSW CL	FSW CL/OP
CLOSED	opens the leaves	opens leaf 1	no effect	no effect (OPEN disabled)	no effect (OPEN disabled)	no effect	no effect (OPEN disabled)
OPENING	stops operation (1)	stops operation	recloses leaves immediately	stops operation	immediately reverses at closure	no effect	stops and opens at release (OPEN stops - saves CLOSE)
OPEN	recloses leaves immediately (1)	recloses leaves immediately	recloses leaves immediately	no effect (OPEN/CLOSE disabled)	no effect	no effect (CLOSE disabled)	no effect (OPEN/CLOSE disabled)
CLOSING	stops operation	stops operation	no effect	stops operation	no effect	reverses at opening	stops and opens at release (OPEN stops - saves CLOSE)
BLOCKED	restarts moving in opposite direction. Always closes after STOP	restarts moving in opposite direction. Always closes after STOP	closes leaves	no effect (OPEN/CLOSE disabled)	no effect (OPEN disabled)	no effect (CLOSE disabled)	no effect (OPEN stops - saves CLOSE)

(1) if the cycle began with OPEN-B (leaf 1), both leaves are activated at opening

LOGIC "AP"	PULSES						
SYSTEM STATUS	OPEN A	OPEN B	CLOSE	STOP	FSW OP	FSW CL	FSW CL/OP
CLOSED	opens and closes after pause time	opens leaf 1 and closes after pause time	no effect	no effect (OPEN disabled)	no effect (OPEN disabled)	no effect	no effect (OPEN disabled)
OPENING	stops operation (1)	stops operation	recloses leaves immediately	stops operation	reverses at closing (saves OPEN)	no effect	stops and opens at release (OPEN stops - saves CLOSE)
OPEN IN PAUSE	stops operation (1)	stops operation	recloses leaves immediately	stops operation	no effect	recharges pause time (CLOSE disabled)	recharges pause time (CLOSE disabled)
CLOSING	reopens leaves immediately	reopens leaves immediately	no effect	stops operation	no effect	reverses at opening (see DS1-SW8)	stops and opens at release (OPEN stops - saves CLOSE)
BLOCKED	closes leaves	closes leaves	closes leaves	no effect (OPEN/CLOSE disabled)	no effect (OPEN disabled)	no effect (CLOSE disabled)	no effect (OPEN/CLOSE disabled)

(1) if the cycle began with OPEN-B (leaf 1), both leaves are activated at opening

LOGIC "SP"	PULSES						
SYSTEM STATUS	OPEN A	OPEN B	CLOSE	STOP	FSW OP	FSW CL	FSW CL/OP
CLOSED	opens and closes after pause time	opens leaf 1 and closes after pause time	no effect	no effect (OPEN disabled)	no effect (OPEN disabled)	no effect	no effect (OPEN disabled)
OPENING	stops operation (1)	stops operation	recloses leaves immediately	stops operation	reverses at closure	continues to open and recloses immediately	stops and opens after release and closes immediately at end (OPEN stops - saves CLOSE)
OPEN IN PAUSE	recloses leaves immediately (1)	recloses leaves immediately	recloses leaves immediately	stops operation	no effect	stops and, at release, closes	stops and, at release, closes
CLOSING	stops operation	stops operation	no effect	stops operation	no effect	reverses at opening	stops and opens at release (saves CLOSE)
BLOCKED	restarts moving in opposite direction. Always closes after STOP	restarts moving in opposite direction. Always closes after STOP	recloses leaves immediately	no effect (OPEN/CLOSE disabled)	no effect (OPEN disabled)	no effect (CLOSE disabled)	no effect (OPEN/CLOSE disabled)

(1) if the cycle began with OPEN-B (leaf 1), both leaves are activated at opening

LOGIC "B"	PULSES						
SYSTEM STATUS	OPEN A	OPEN B	CLOSE	STOP	FSW OP	FSW CL	FSW CL/OP
CLOSED	opens the leaves	no effect	no effect	no effect (OPEN disabled)	no effect (OPEN disabled)	no effect	no effect (OPEN disabled)
OPENING	no effect	closes leaves	closes leaves	stops operation	reverses at closure	no effect	stops and, at release, closes (saves OPEN/CLOSE)
OPEN	no effect	closes leaves	closes leaves	no effect (OPEN/CLOSE disabled)	no effect	no effect (CLOSE disabled)	no effect (OPEN/CLOSE disabled)
CLOSING	opens the leaves	no effect	no effect	stops operation	no effect	reverses at opening	stops and opens at release (saves OPEN/CLOSE)
BLOCKED	opens the leaves	closes leaves	closes leaves	no effect (OPEN/CLOSE disabled)	no effect (OPEN disabled)	no effect (CLOSE disabled)	no effect (OPEN/CLOSE disabled)

LOGIC "C"	CONTINUOUS COMMANDS			PULSES			
SYSTEM STATUS	OPEN A	OPEN B	CLOSE	STOP	FSW OP	FSW CL	FSW CL/OP
CLOSED	opens the leaves	no effect	no effect	no effect (OPEN disabled)	no effect (OPEN disabled)	no effect	no effect (OPEN disabled)
OPENING	no effect	closes leaves	closes leaves	stops operation	reverses at closure	no effect	stops and, at release, closes (saves OPEN/CLOSE)
OPEN	no effect	closes leaves	closes leaves	no effect (OPEN/CLOSE disabled)	no effect	no effect (CLOSE disabled)	no effect (OPEN/CLOSE disabled)
CLOSING	opens the leaves	no effect	no effect	stops operation	no effect	reverses at opening	stops and opens at release (saves OPEN/CLOSE)
BLOCKED	opens the leaves	closes leaves	closes leaves	no effect (OPEN/CLOSE disabled)	no effect (OPEN disabled)	no effect (CLOSE disabled)	no effect (OPEN/CLOSE disabled)

**LIMITED WARRANTY****To the original purchaser only:**

FAAC International, Inc., warrants, for twenty-four (24) months from the date of invoice, the gate operator systems and other related systems and equipment manufactured by FAAC S.p.A. and distributed by FAAC International, Inc., to be free from defects in material and workmanship under normal use and service for which it was intended provided it has been properly installed and operated.

FAAC International, Inc.'s obligations under this warranty shall be limited to the repair or exchange of any part of parts manufactured by FAAC S.p.A. and distributed by FAAC International, Inc. Defective products must be returned to FAAC International, Inc., freight prepaid by purchaser, within the warranty period. Items returned will be repaired or replaced, at FAAC International, Inc.'s option, upon an examination of the product by FAAC International, Inc., which discloses, to the satisfaction of FAAC International, Inc., that the item is defective. FAAC International, Inc. will return the warranted item freight prepaid. The products manufactured by FAAC S.p.A. and distributed by FAAC International, Inc., are not warranted to meet the specific requirements, if any, of safety codes of any particular state, municipality, or other jurisdiction, and neither FAAC S.p.A. or FAAC International, Inc., assume any risk or liability whatsoever resulting from the use thereof, whether used singly or in combination with other machines or apparatus.

Any products and parts not manufactured by FAAC S.p.A. and distributed by FAAC International, Inc., will carry only the warranty, if any, of the manufacturer. This warranty shall not apply to any products or parts thereof which have been repaired or altered, without FAAC International, Inc.'s written consent, outside of FAAC International, Inc.'s workshop, or altered in any way so as, in the judgment of FAAC International, Inc., to affect adversely the stability or reliability of the product(s) or has been subject to misuse, negligence, or accident, or has not been operated in accordance with FAAC International, Inc.'s or FAAC S.p.A.'s instructions or has been operated under conditions more severe than, or otherwise exceeding, those set forth in the specifications for such product(s). Neither FAAC S.p.A. nor FAAC International, Inc., shall be liable for any loss or damage whatsoever resulting, directly or indirectly, from the use or loss of use of the product(s). Without limiting the foregoing, this exclusion from liability embraces a

purchaser's expenses for downtime or for making up downtime, damages for which the purchaser may be liable to other persons, damages to property, and injury to or death of any persons.

FAAC S.p.A. or FAAC International, Inc., neither assumes nor authorizes any person to assume for them any other liability in connection with the sale or use of the products of FAAC S.p.A. or FAAC International, Inc. The warranty herein above set forth shall not be deemed to cover maintenance parts, including, but not limited to, hydraulic oil, filters, or the like. No agreement to replace or repair shall constitute an admission by FAAC S.p.A. or FAAC International, Inc., of any legal responsibility to effect such replacement, to make such repair, or otherwise. This limited warranty extends only to wholesale customers who buy directly through FAAC International, Inc.'s normal distribution channels. FAAC International, Inc., does not warrant its products to end consumers.

Consumers must inquire from their selling dealer as to the nature and extent of that dealer's warranty, if any. This warranty is expressly in lieu of all other warranties expressed or implied including the warranties of merchantability and fitness for use. This warranty shall not apply to products or any part thereof which have been subject to accident, negligence, alteration, abuse, or misuse or if damage was due to improper installation or use of improper power source, or if damage was caused by fire, flood, lightning, electrical power surge, explosion, wind storm, hail, aircraft or vehicles, vandalism, riot or civil commotion, or acts of God.