

## HEADQUARTERS

### ITALY

FAAC spa  
Via Calari 10 - 40069 Zola Predosa (BO)  
Tel. +39 051 61724 - Fax +39 051 758518  
info@faac.it - www.faac.it

### AUSTRALIA

FAAC AUSTRALIA PTY LTD  
Homebush – Sydney, Australia  
tel. +61 2 87565644  
fax +61 2 87565677  
www.faac.com.au

### AUSTRIA

FAAC GE.S. M.B.H.  
Wals – Siezenheim, Austria  
tel. +43 662 8533950  
fax +43 662 85339520  
www.faac.at

### BENELUX

FAAC BENELUX  
Brugge, Belgium  
tel. +32 50 320202  
fax +32 50 320242  
www.faacbenelux.com

### CHINA

FAAC SHANGHAI  
Shanghai, Cina  
tel. +86 21 68182970  
fax +86 21 68182968  
www.faac.com.cn

### SPAIN

F.A.A.C. SA  
Madrid, España  
tel. +34 91 6613112  
fax +34 91 6610050  
www.faac.es

F.A.A.C. SA Delegación Cataluña  
Barcelona, España  
tel. +34 93 4362000  
fax +34 93 4368225  
www.faac.es

### FRANCE

FAAC FRANCE  
Corbas, France  
tel. +33 4 72218700  
fax +33 4 72218701  
www.faac.fr

### FRANCE

FAAC NORD S.A.S.  
Massy, France  
tel. +33 1 69191620  
fax +33 1 69191621  
www.faac.fr

### GERMANY

FAAC GMBH  
Freilassing, Germany  
tel. +49 8654 49810  
fax +49 8654 498125  
www.faac.de

### INDIA

FAAC INDIA PVT. LTD  
Noida – Delhi, India  
tel. +91 120 3934100/4199  
fax +91 120 4212132  
www.faacindia.com

### MIDDLE EAST

FAAC MIDDLE EAST BRANCH  
Dubai Airport Free Zone, UAE  
tel. +971 42146733  
fax +971 42146734  
www.faac.ae

### POLAND

FAAC POLSKA SPZO. O  
Warszawa, Polska  
tel. +48 22 8141125  
fax +48 22 8142024  
www.faac.pl

### SCANDINAVIA

FAAC SCANDINAVIA AB  
Bankeryd, Sweden  
tel. +46 36 376860  
fax +46 36 370780  
www.faac.se

### SWITZERLAND

FAAC AG  
Altdorf, Switzerland  
tel. +41 41 8713440  
fax +41 41 8713484  
www.faac.ch

### UNITED KINGDOM

FAAC UK LTD.  
Basingstoke Hampshire, UK  
tel. +44 1256 318100  
fax +44 1256 318101  
www.faac.co.uk

### USA

FAAC INTERNATIONAL INC  
Jacksonville, USA  
tel. +1 904 448 8952  
fax +1 904 448 8958  
www.faacusa.com

Fullerton, USA  
tel. +1 714 446 9800  
fax +1 714 446 9898  
www.faacusa.com

Headquarter & East Coast Operations  
FAAC International Inc.  
5151 Sunbeam Road  
Suites 9-11  
Jacksonville, Florida 32257  
Tel. 866 925 3222 Toll Free  
Tel. 904 448 8952  
Fax 904 448 8958

West Coast Operations  
FAAC International Inc.  
357 South Acacia Avenue  
Unit 357  
Fullerton, California 92831  
Tel. 800 221 8278 Toll Free  
Tel. 714 446 9800  
Fax 714 446 9898



2,000 - 03/2012 The descriptions and illustrations contained in the present brochure are not binding. FAAC reserves the right to undertake product technical modifications without prior notice.



## S418

Electro-mechanical 24V operator  
for swing-leaf gates

## A NEW OPERATOR FOR SWING-LEAF GATES: EASY TO INSTALL AND WITH A UNIQUE DESIGN

- Long stroke + new multi-position attachments with fittings
- For single-leaf up to 12 ft.
- Integrated mechanical stops
- New control board with anti-crushing system and electronic encoder for inversion on obstacles
- Residential use



### EASY TO INSTALL:

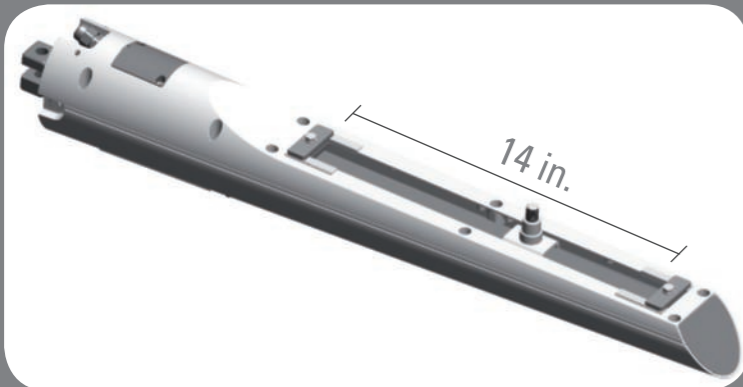

Increased flexibility in the installation dimensions thanks to the 14 in. (350 mm) long stroke, 16 in. (400 mm) without mechanical stops.



Suits a wide range of installations thanks to the multi-position attachments.



### E024U 24V BOARD



#### FEATURES:

- UL991 safety standard compliant
- Powerful and efficient Switching Power Supply
- Easy programming with trimmers and dip switches
- One pushbutton automatic self learning
- Self resetting fuses
- Stand By mode for efficient power use
- Built in battery backup

#### SPECIFICATIONS:

AC input ratings:	115V - 60Hz - 2.5A
Stand By Power:	4W
Motor Output Current:	7A each
Accessory Power:	24 Vdc - 500 mA
Operating Temperature:	-4 °F - + 131 °F

#### AVAILABLE MODEL

Part Number	Description
104301	S418 24V Electromechanical Operator

#### TECHNICAL SPECIFICATIONS S418

Input Voltage	24 Vdc	Type and frequency of use at 20°C	Residential use
Nominal power	35 W	Operating ambient temperature	-4°F ÷ 131°F (-20°C ÷ +55°C)
Max Thrust Force	405 lbf	Weight	13 lbs. (6 Kg)
Rod stroke	14 in. (350 mm), 16 in. (400 mm) without mechanical stops	Dimensions (L x D x H)	33 x 4 x 5 in. (825 x 104 x 125 mm)
Rod extension speed	0.75 in./sec	Protection class	IP44
Leaf max length	12 ft.	Opening and closing mechanical stops	YES
Leaf max weight	500 lbs.		